

CHASSIS 11AK10
SERVICE MANUAL

FOR ALL MODELS

1997

DO NOT CHANGE ANY MODULE UNLESS THE SET IS SWITCH OFF.

The mains supply side of the switch mode power supply transformer is live.

Use an isolating transformer.

The receivers fulfill completely the safety requirements.

Safety precautions

Servicing of this TV should only be carried out by a qualified person.

- Components marked with the warning symbol on the circuit diagram are critical for safety and must only be replaced with an identical component.
- Power resistor and fusible resistors must be mounted in an identical manner to the original component.
- When servicing this TV, check that the EHT does not exceed 26 KV.

TV set switched off:

Make short-circuit between HV-CRT clip and CRT ground layer.

Short C808 (150 μ F) before changing IC801 or other components in primary side of SMPS.

Measurements

Voltage readings and oscilloscope traces are measured under following conditions.

Antenna Signal 60dBuV from colorbar generator. (100% white, 75% color saturation)

Brightness, contrast, color set for a normal picture

Mains supply, 220V AC, 50 Hz.

PERI-TV SOCKET

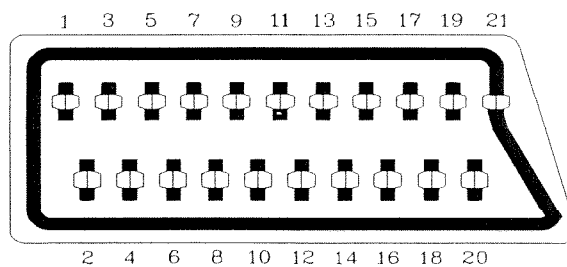

SCART 1 (SC401)

1	AF right output	0.5Vrms / 1K
2	AF right input	0.5Vrms / 10K
3	AF left output	0.5Vrms / 1K
4	Ground AF	
5	Ground blue	
6	AF left input	0.5Vrms / 1K
7	Blue input	0.7Vpp / 75
8	AV switching input	9.5-12Vdc / 10
9	Ground green	
10	-	
11	Green input	0.7Vpp / 75
12	-	
13	Ground red	
14	Ground blanking	
15	Red input	0.7Vpp / 75
16	Blanking input	1.3Vpp / 75
17	Ground CVS output	
18	Ground blanking input	
19	CVS output	1Vpp / 75
20	CVS input	1Vpp / 75
21	Ground	

SCART 1 (SC402) (OPTIONAL)

1	AF right output	0.5Vrms / 1K
2	AF right input	0.5Vrms / 10K
3	AF left output	0.5Vrms / 1K
4	Ground AF	
5	Ground blue	
6	AF left input	0.5Vrms / 1K
7	-	
8	-	
9	Ground green	
10	-	
11	-	
12	-	
13	Ground red	
14	Ground blanking	
15	-	
16	-	
17	Ground CVS output	
18	Ground blanking input	
19	CVS output	1Vpp / 75
20	CVS input	1Vpp / 75
21	Ground	

1. INTRODUCTION

11AK10 is a 90 degree chassis capable of driving 20 and 21 inch tubes at appropriate beam currents. The chassis is capable of working in PAL. The sound system is capable of giving 2.5-3.5watts RMS output into a load of 16ohms.

One four page simple TELETEXT, TOPEXT, FASTEXT is provided. The chassis is equipped with 21-pin scart connectors can accept via scart the SVHS format from VCRs so equipped.

2. SMALL SIGNAL PART WITH TDA8362A :

The TDA8362A combines all small signal functions required for a colour TV receiver, except tuning.

2.1. Vision IF amplifier, video demodulator and identification circuit :

The vision IF amplifier consists of three AC-coupled differential stages. The gain control per stage is more than 20dB, which results in a total gain control of 64dB min. The IF amplifier inputs can be coupled directly to the SAW filter output. The input impedance is 2 Kohm in parallel with 3pF. The input sensitivity for on-set of AGC is 70 μ V (typ.), for IF frequencies between 38.9MHz and 58.75MHz. The reference carrier for the video demodulator is obtained via passive regeneration of the picture carrier. The reference tuned circuit is connected between pin 2 and 3. The IC can handle positive and negative modulated signals, the polarity of the modulation can be switched at pin 1. A transmitter identification circuit operates independently of the synchronization circuit, to allow separate use of the front-end section and the display section of the TDA8362A. The output voltage at pin4 will be high with transmitter identification and low without identification (sound muted).

2.2. AGC , tuner AGC and AFC :

The AGC detector operates at top-synch level for signals with negative modulation and at peak-white level for positive modulated signals. For positive modulated signals the AGC time constant is long to avoid visible variations of the video output signal. To obtain an acceptable AGC speed with positive modulation an extra circuit checks whether the AGC detector is activated every frame period. The speed will be increased if this circuit detects that the video output signal has not reached 80% of peak white level for approximately 100ms. Externally a diode (D201) takes care that the tuner AGC voltage can be reduced rather quickly, which is only required if positive modulated signals have to be processed. The tuner AGC take-over point can be set by adjusting the DC voltage at pin 49, with a potentiometer of 10Kohm (VR402). The tuner AGC (pin 47) is an open collector output stage with an output swing of 2mA min. The voltage swing, required by the tuner, can be obtained with an external resistive network, connected at pin 47. Pin 47 may rise 2V above the actual supply voltage, without damaging the IC. This feature is provided because most tuners require a 9V AGC voltage level for min gain. The AFC circuit is driven by the same reference signal as the video demodulator. A sample and hold circuit avoids video break-through from the video demodulator to the AFC voltage. The AFC output voltage range is from 0 to Vcc.

2.3. Sound circuit :

The sound carrier which is present at the video output pin 7 is fed via the sound bandpass to the sound input at pin 5. This pin has a double function; sound IF input (AC) and volume control (DC). The filtered intercarrier signal is fed to an amplifier / limiter circuit and is demodulated by a PLL demodulator. This PLL demodulator tunes automatically to the incoming frequency, hence no alignment is required. The AF signal (pin 50) has an amplitude of 350 mV_{rms} at maximum volume control setting. The volume control setting is between 0 and 5V, volume control is logarithmic. The deemphasis capacitor (C401) is connected externally at pin 1. The non-controlled audio signal (Peri-television) is also obtained from pin 1 via an amplifier stage (Q406). Audio input signal from an external source (SCART) with an amplitude up to 350m V_{rms} (+/- 6dB) can be fed to pin6. The audio switch is controlled via the chroma input pin 16, as described in Chapter 8. The volume control operates upon the external audio input signal, when the TDA8362A is switched to the external mode.

2.4. Horizontal and vertical synchronization :

The incoming video signal, pin 13 for the internal signal and pin 15 for an external CVBS signal, is fed to the synchronization separator circuit. Internally the black level and the top synch level are detected, next the synchronization pulses are amplified to a fixed level and sliced at 50% of that level. The separated synchronization pulses are fed to the first phase detector circuit and to the coincidence detector. The components which determine the loop gain of the first phase detector are connected at pin 40 (C422, C423 and R438) The coincidence detector is only used to detect whether the line oscillator is synchronised. When the IC is operating in internal mode, this information is fed to the ident pin as transmitter identification. The line oscillator is running at twice the line frequency and is derived from the X-tal oscillator frequency of the colour decoder, consequently no adjustment is required. The second phase detector generates the pulses for the horizontal driver stage (pin 37). The loop filter capacitor (C424) is connected at (pin 39). Horizontal shift can be obtained by a potentiometer (VR401), a series resistor (R440).

The TDA8362A has a separate start-up circuit for the horizontal oscillator (pin 36). The vertical drive pulses (pin 44) are generated by a divider circuit. The vertical ramp generator components are connected at pin 43. AC and DC feedback voltage from the vertical deflection stage must be connected at pin 42.

2.5. Integrated video filters :

The TDA8362A has an alignment-free internal chroma bandpass and trap circuit. These filters are realised by means of gyrator circuit and they are tuned by tracking to the frequency of the X'tal controlled oscillator. The luminance delay is also realised by gyrator circuits. For SECAM an extra delay is built-in to adjust for the correct delay of the luminance signal.

2.6. Colour decoder :

The colour decoder contains an alignment-free X-tal oscillator, a dual killer circuit and the colour difference signals demodulators. The decoder adapts automatically for PAL and NTSC signals. Two X-tal pins are present so no external switching is required. With the SECAM add-on decoder TDA8395 an alignment free multi-standard decoder with automatic selection is built. The burst phase detector locks the X-tal oscillator with the burst signal.

2.7. RGB controller :

The colour difference signals are matrixed with the luminance signal to obtain RGB output signals (pin 18, 19 and 20). External RGB signals (pin 22, 23 and 24) coming from the Peri-television connector are interfaced by linear amplifiers. The contrast and brightness control and the peak white limiter operate on internal and external signals as well as RGB signals. The data insertion pin 21 has a second detection level at 4V. Above this level the RGB outputs are blanked. In this way OSD signals can be supplied directly to the inputs of the video output stages without any interaction to the RGB outputs of the colour decoder part of the TDA8362A. The output signal has an amplitude of about 2 V_{BL-WH} at nominal input signals and nominal control settings. The black current stabilisation is realized by means of a feedback from the video output amplifiers to the RGB output circuit. The black current of the three guns of the picture tube is internally measured and stabilised. The leakage current is measured during the first line and the following 3 lines, the 3 guns are adjusted to the required level. Maximum acceptable leakage current is +/- 100µA. The nominal value of the black current is 10µA. The maximum current that can be supplied to the measuring input (pin 14) is 250µA. The currents flowing into this pin will be higher during scan. For this reason, it is necessary that the excessive current is by-passed by means of an external clamping circuit. A resistor in series (R473) and a capacitor (C410) are connected to pin 14. The black current stabilisation circuit is not activated when the TV receiver is switched on and the RGB outputs are blanked; contrast, brightness control pins are short circuited. Only during the measuring lines, the output will supply a voltage of 5 V to the video output stage so that it can be detected whether the picture tube is warming up. When the current supplied to the measuring input (pin 14) exceeds 190µA, the stabilisation circuit is activated and the contrast and brightness control pins are released. The switch-on behaviour of the picture is determined by the external time constant of the contrast control network.

2.8. Switches for external audio, CVBS and S-VHS signals :

The audio and CVBS switches are controlled via the chroma input pin 16, according to the following table :

Level pin 16	Int.CVBS	Ext.CVBS	Chroma	Chr.trap	Audio
DCV (INT.)	on	off	off	on	int.
3V S-VHS	off	on(Y)	on	off	ext.
DC7.5V (EXT.)	off	on(CVBS)	off	on	ext.

3. TUNER

Either a UHF-only TFK 3011 or a UHF/VHF 2000 KHC is used as tuner. The frequency range is

SYSTEM	C.C.I.R	
	off-air	cable
VHF - LOW	51MHz to 65MHz	S1 to S6
VHF - HIGT	178MHz to 227MHz	S7 to S41
UHF	474MHz to 858MHz	-

The tuner has a voltage gain of approximately 40dB with a gain reduction capability of typically 40dB for band 1 and 3 and a minimum AGC of 30dB for band 4 and 5. It has a noise figure of typically 7dB for band 1 and 3, 8dB for band 4 and 9dB for band 5.

4. SECAM DECODER TDA8395 (FOR MODELS WITH SECAM SYSTEM ONLY)

The SECAM decoder TDA8395 which is used in conjunction with the TDA8362A includes the Cloche filter, demodulator and identification circuit. The resonance frequency of the Cloche filter is controlled during the calibration period and offset during scan for the right resonance frequency. The required reference frequency for calibration is connected at pin 1 and is obtained from the TDA8362A (pin 32). The two-level sandcastle pulse has to be connected at pin 15 (TDA8362A pin38) and is used for generation of the blanking periods and provides clock information for the identification circuit.

The chroma signal at pin 16 connected to pin 27 of the TDA8362A, is demodulated by a PLL demodulator, which uses the reference frequency and a band gap reference to force the PLL to the desired demodulation characteristic.

5. BASEBAND DELAY LINE TDA4661

The TDA4661 are integrated base band delay lines of 64 μ S for colour TV receivers. It is connected to the TDA8362A and TDA8395 without the need of switches and alignments. The TDA4661 consists of two main blocks:

- Two comb filters with a delay time of 64 μ S.
- Internal clock generation of 3MHz, line locked via the sandcastle pulse.

The TDA4661 operates according to the mode demanded by the colour transmission standard. In the PAL mode it operates as a geometric adder to satisfy the requirements of PAL demodulation and in the SECAM mode the delay line repeats the colour difference signal on consecutive horizontal scan lines.

6. VERTICAL OUTPUT STAGE WITH TDA3653B

The TDA3653B is a vertical deflection output circuit for drive of various deflection systems with currents up to 1.5A_{p-p}. The output pin is pin 5. The output power transistors are protected by the cooperation of thermal protection circuit, the current-voltage detector, the short-circuit protection and the special measures in the internal circuit layout. Pin 1 is the input for the driver of the output stage. The signal at pin 1 is also applied via external resistors to pin 3 which is the input of a switching circuit. When the flyback starts, this switching circuit rapidly turns off the lower output stage and so limits the turn-off dissipation. The amplitude of the flyback voltage which is present at pin 8 is determined by the value of the external resistor at pin 8. When there is no deflection current and the flyback generator is not activated, the voltage at pin 8 reduces to less than 1.8V. The guard circuit will then produce a DC voltage at pin 7, which can be used to blank the picture tube and thus prevent screen damage. The internal voltage stabilizer provides a stabilized supply of 6V to drive the output stage, which prevents the drive current of the output stage being affected by supply voltage variations.

7. HORIZONTAL DEFLECTION STAGE

The horizontal drive pulses, from pin 37 of the TDA8362A, are connected to base of driver transformer Q601 via resistor R439. The base current of the driver transistor is supplied via R601 (pin 37 is an open-collector output). The driver transformer (TR601) drives the BU506D deflection transistor (Q602). TR602 is the EHT transformer. The 112V supply voltage for the transformer is connected at pin 3. TR602 generates the EHT-, focus- and G2- voltage, required by the picture tube. Furthermore the 200V supply and heater voltages are derived from this transformer. The beam current information from pin 7 of TR602 is used for reducing the contrast at too high beam currents, for stabilizing the voltages derived from the power supply and for stabilization of the vertical amplitude. The flyback voltage is AC-coupled and clipped between +8V and ground by diodes D601 and D602 to obtain a well-shaped flyback pulse for feedback to the TDA8362A (pin 38).

8. SOUND OUTPUT STAGE TDA2611A

TDA2611A is used as the AF output amplifier. It is supplied by +24V coming from a separate winding in the SMPS transformer. Pin 50 of the TDA8362 is AC-coupled to the input pin 7 of the TDA2611A via a resistor divider. Maximum audio output power for 1 KHz signal with 30% modulation is 1.5W.

9. MICROCONTROLLER (CTV322S, CTV422M)

A. CTV322S is a TV receiver control system using all the functions of a PCA84C641 microcontroller. The system has Voltage Synthesis Tuning (VST). Sound and picture are controlled by the five DACs of the PCA84C641. The system is independent of the TV transmission standards. Control of a four-page teletext decoder is an option in the basic system. A 2K memory which allows 90 programmes to be stored is used (IC1002).

CTV322S has the following features:

- Voltage synthesis tuning via a 14-bit DAC
- On-screen display
- Control of two transmission standards
- Direct control of four-page teletext decoder
- Full peri-TV switching

B. CTV422M is a TV receiver control system using all the functions of a PCA84C841 microcontroller. The system has Voltage Synthesis Tuning (VST). Sound and picture are controlled by the five DACs of the PCA84C841. The system is independent of the TV transmission standards. Control of a four-page teletext decoder is an option in the basic system. A 2K memory which allows 90 programmes to be stored is used (IC502).

CTV422M has the following features:

- Voltage synthesis tuning via a 14-bit DAC
- On-screen display
- Control of two transmission standards
- Direct control of four-page teletext decoder
- Full peri-TV switching

10. POWER SUPPLY (SMPS)

The DC voltages required at various parts of the chassis are provided by an SMPS transformer controlled by the IC TDA4605-2 which is designed for driving, controlling and protecting the switching transistor BUZ77B of SMPS. This transformer produces 112V for FBT input, 33V for tuning circuitry of microcontroller, 26V for audio output, 26V for vertical output (field scan) and for tuner and some other ICs and transistors. This 12V is also used to obtain 8V by means of the regulator LM7808 for TDA8362A and some other ICs and transistors and 5V by means of regulator for teletext circuitry and 5V is obtained from 12V out for controller.

11. CRT BASEBOARD

When RGB signals enter the input of the video amplifier stage (CRT baseboard), they are amplified by means of three symmetrical class-B type video amplifier stages. For this purpose, three BF869S high-voltage, video output power transistors are used. So, high gain-bandwidth product is achieved. Furthermore, voltage changes at the outputs of amplifiers caused by temperature variations are compensated by means of an additional circuitry. Black current information (BCI) is sent to TDA8362A (Refer to TDA8362A RGB).

12. TELETEXT BOARD

There are three teletext options:

- Simple text (1 page) using SAA5254P/T
- Simple text (4 page) using SAA5246 + 8K8 RAM
- FASTEXT (4 page) using SAA5246 + 8K8 RAM + PCF84C81

SPECIFICATIONS

POWER SUPPLIES

Nominal : 220-240V AC 50Hz. The chassis is fully mains isolated and is stabilized across mains voltage range from 175V to 265V for less than 0.75 % change in picture size. No mains input adjustment is required.

POWER CONSUMPTION

Typically : 50 W, Maximum : 70 W (for 20" and 21" models)

FREQUENCY COVERAGE

Hyperband (VHF CH 2 to UHF CH 69 including CATV) : 47-862 MHz

UHF (CH 21-69) : 471-862 MHz

SENSITIVITY

34 dBmV or less for any channel with a locked colour picture

MAXIMUM SIGNAL INPUT

95 dBmV or more for any channel

IF FREQUENCIES	(in MHz)	
	VISION	SOUND
B/G (EUROPE) :	38.9	33.4
I (UK) :	39.5	33.5
L' (FRANCE) :	32.7	39.2
L (FRANCE) :	39.2	32.7
D/K (RUSSIA)	38.0	31.5

AUDIO OUTPUT

Maximum : 2.5W RMS for 20" and 21" models
(At less than 10 % THD for 1 KHz, 30 % modulation factor)

BEAM CURRENT LIMITING

1200 μ A for 20" and 21" models

EHT

Maximum: 26 KV for 20" and 21" models

SERVICING ADJUSTMENTS AND ALIGNMENTS

The following preset adjustment procedures are not required during installation and should be made, if necessary, after servicing.

WARNING

EHT SHOCK HAZARD : The EHT must be safely discharged before attempting to disconnect the EHT lead from the tube anode.

Clip one end of a convenient lead, such as a meter lead, to the tube earthing strap on the tube body, fold back the suction cap and discharge the EHT through the lead. Press in one side of the spring clip which protects into the tube cavity to ease removal of the EHT connector.

IMPORTANT

Do not disturb the tube neck adjustments as these have been set for optimum performance during the tube manufacture.

Before attempting the following adjustments, the receiver should be tuned with the brightness, contrast and colour controls adjusted for the best picture and all measurements are to be made after a warm-up period of approximately 5 minutes, unless stated otherwise.

- 60 dBmV signal at any channel frequency
- Color bar pattern and 1KHz sound signal
- Mains 220-240V AC, 50Hz

The adjustments should be carried out in the following order for convenience.

SMPS SYSTEM VOLTAGE

- 1) Set the BCS (Brightness, Contrast, Saturation) and VOL (Volume) to minimum.
- 2) Check the voltage at the shorted pins of socket PL602 (TP1)
- 3) If necessary, adjust VR801 $115 \pm 0.5V_{DC}$ (20" and 21" models)
- 4) Set the BCS and VOL to normal picture and sound

VISION DEMODULATOR AND AFC

- 1) Set the pattern generator for 10mV, 38.9 MHz (B/G models) or 39.5 MHz (for I models) or 38.0 MHz (for D/K models) RF output
- 2) Connect the RF output of the pattern generator to any one input of SAW filter and connect the other input of SAW filter to ground through 10 nF capacitor (No antenna input applied)
- 3) Check the voltage at the base of Q201 (TP2)
- 4) Adjust VL401 for $3.5 \pm 0.1 V_{DC}$

2) PICTURE GEOMETRY AND FOCUS

- 1) Set the pattern generator for centre-cross, circle and cross-hatch composite pattern.
- 2) Adjust VR702 for vertical size, VR701 for vertical linearity, VR703 for vertical shift, VR401 for horizontal centering and focus potentiometer (on EHT transformer) for optimum focusing.

TUNER AGC

- 1) Check the voltage at pin 1 of TUNER (TP4)
- 2) Adjust VR402 for 1V less than maximum.

SCREEN VOLTAGE

- 1) Set the pattern generator for grey scale.
- 2) Set the BCS (Brightness, Contrast, Saturation) to minimum.
- 3) Measure cathode voltages on the CRT base board by using a 1/1000 probe.
- 4) Adjust screen pot of FBT for $175 \pm 2V$ reading on maximum cathode voltage

CRT BASEBOARD : CUT-OFF VOLTAGES AND WHITE BALANCE

- 1) Set the pattern generator for grey scale.
- 2) Set the BCS (Brightness, Contrast, Saturation) to minimum.

MAIN CHASSIS PLUG IDENTIFICATION, SETTING AND MEASUREMENT POINT

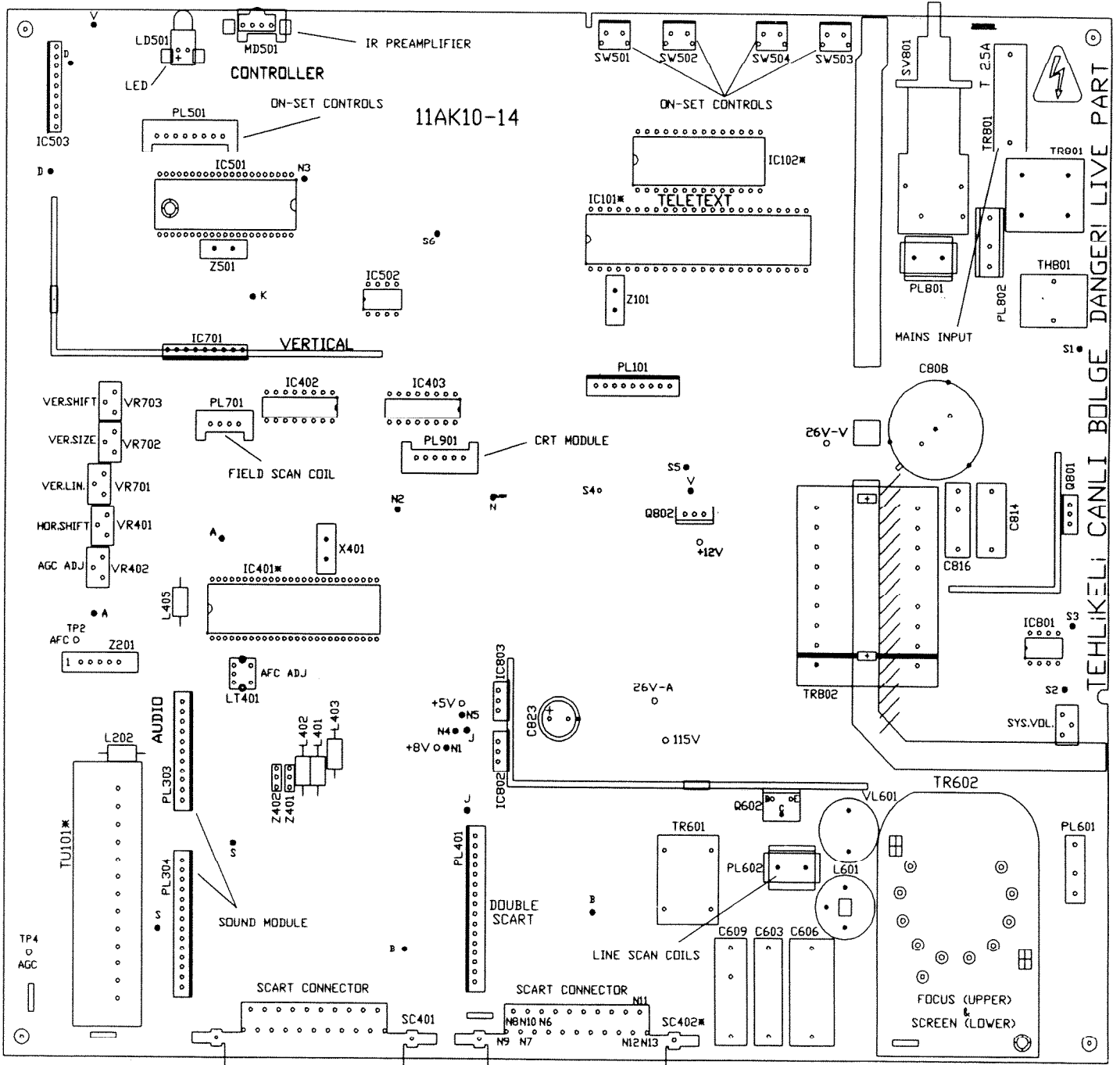

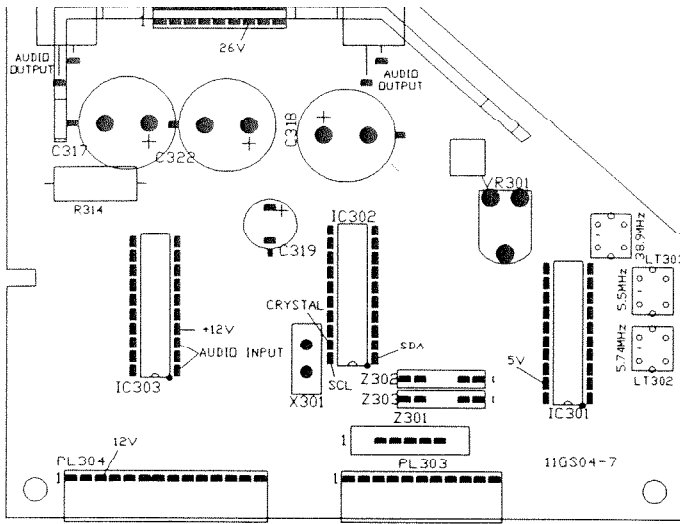

11GS04 GERMAN STEREO MODULE

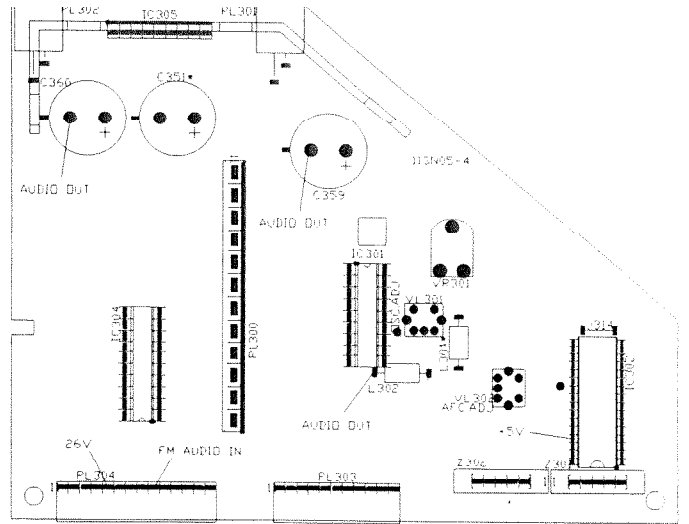

11SN05 SECAM-L NICAM STEREO MODULE

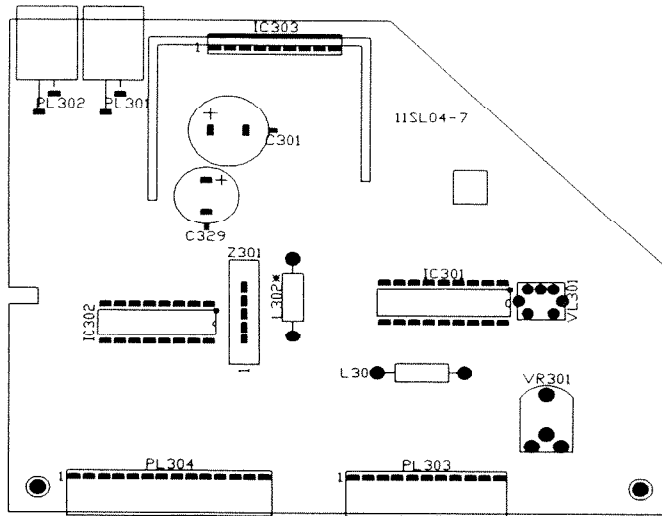

11SL04 SECAM-L MODULE

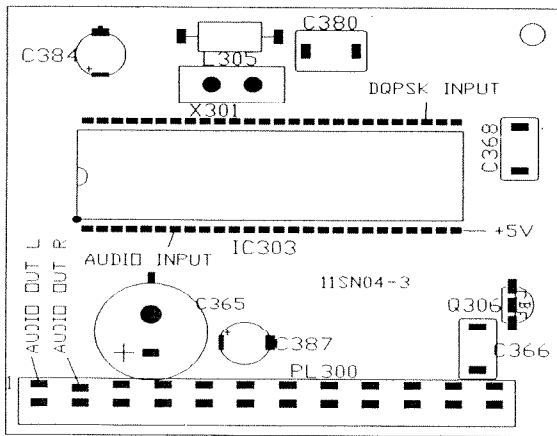

11SN04 SECAM-L NICAM STEREO MODULE

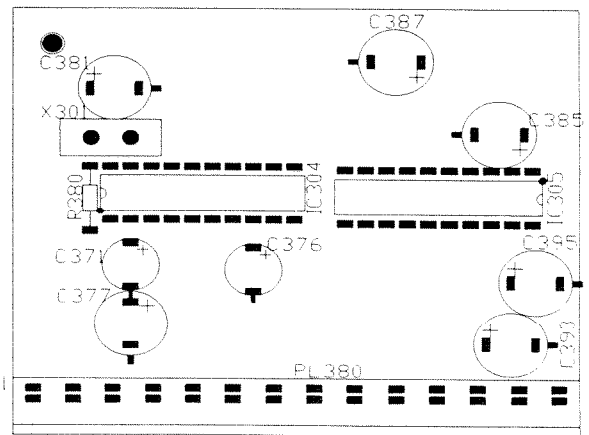

11GSL2 SECAM-L GERMAN STEREO MODULE

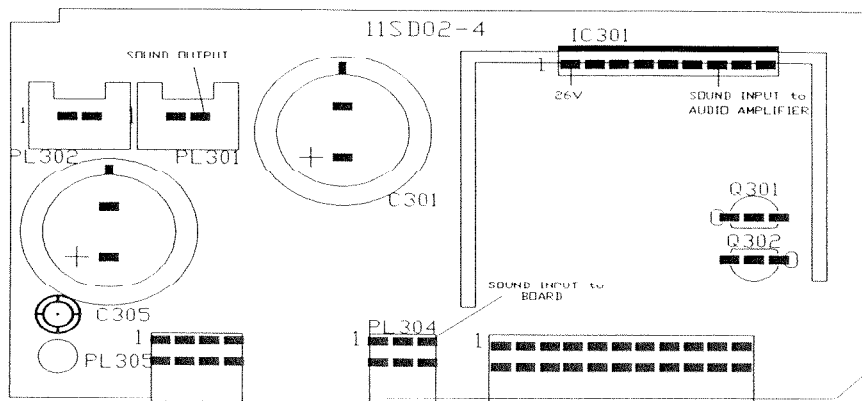

11SD02 SOUND MODULE

MAIN PCB FAULT FINDING GUIDE

AT FIRST CHECK ALL THE SUPPLY VOLTAGES, THEN CHECK FOLLOWING RELEVANT POINTS FOR TROUBLE SHOOTING. TROUBLES SHOULD BE THE SAME AT ALL CHANNELS.

TROUBLE	CHECK POINTS
NO PICTURE, NO SOUND	TUNER VOLTAGES, INPUT/OUTPUT SIGNALS OK Q401, IC401
NO PICTURE, SOUND OK	INT CVBS IN, IC401, SCREEN VOLTAGE
NO COLOUR	IC401, IC402, IC403, X401
NO VERTICAL DEFLECTION	26V, R711, PL701, IC701
VERTICAL LINEARITY	C705, VR701
VERTICAL SIZE	R704, VR702
VERTICAL SHIFT	VR703, R708, Q701, Q702
VERTICAL FOLD	26V, R711
HORIZONTAL LINEARITY	L601, C606
HORIZONTAL SIZE	C603, SYSTEM VOLTAGE (115V)
HORIZONTAL FOLD	SYSTEM VOLTAGE (115V)
FLUE PICTURE	TR602, G3 (FOCUS), EHT, FLAMENT VOLTAGE
DARK PICTURE	TR602 G2 (FOCUS), BRIGNES, CONTRAST VOLTAGE
NOISY PICTURE	AGC VOLTAGE, RF SIGNAL
VERTICAL/HORIZONTAL SYNC.	IC401
INTFRFFRFNCF	TUNER (TU201), 7201
NO SOUND	IC401, (PIN5)
LOW SOUND	IC401 (PIN5, SOUND CONTRDL VOLTAGE), R303, IC301
SOUND DISTORTION	IC301, 26V
POP NOISE	Q301, C307
CONTRAST	IC401 (PIN25)
BRIGHTNESS	IC401 (PIN17)
COLOUR	IC401 (PIN26)
AUTO TUNING	Q501
MEMORY	IC502
BAND SELECT	IC503
NO VIDEO AT SCART	SET AV MODE, CHECK IC401 (PIN5), (PIN6)
NO SOUND AT SCART	IC401 (PIN6)
MISSING CHARACTER AT TELETEXT	SIGNAL AT PIN8 OF IC1101
REMOTE CONTROLLER	BATTERY, IR DIODE, CURRENT PATH OF IR DIODE

GENERAL BLOCK DIAGRAM OF CHASSIS 11AK10

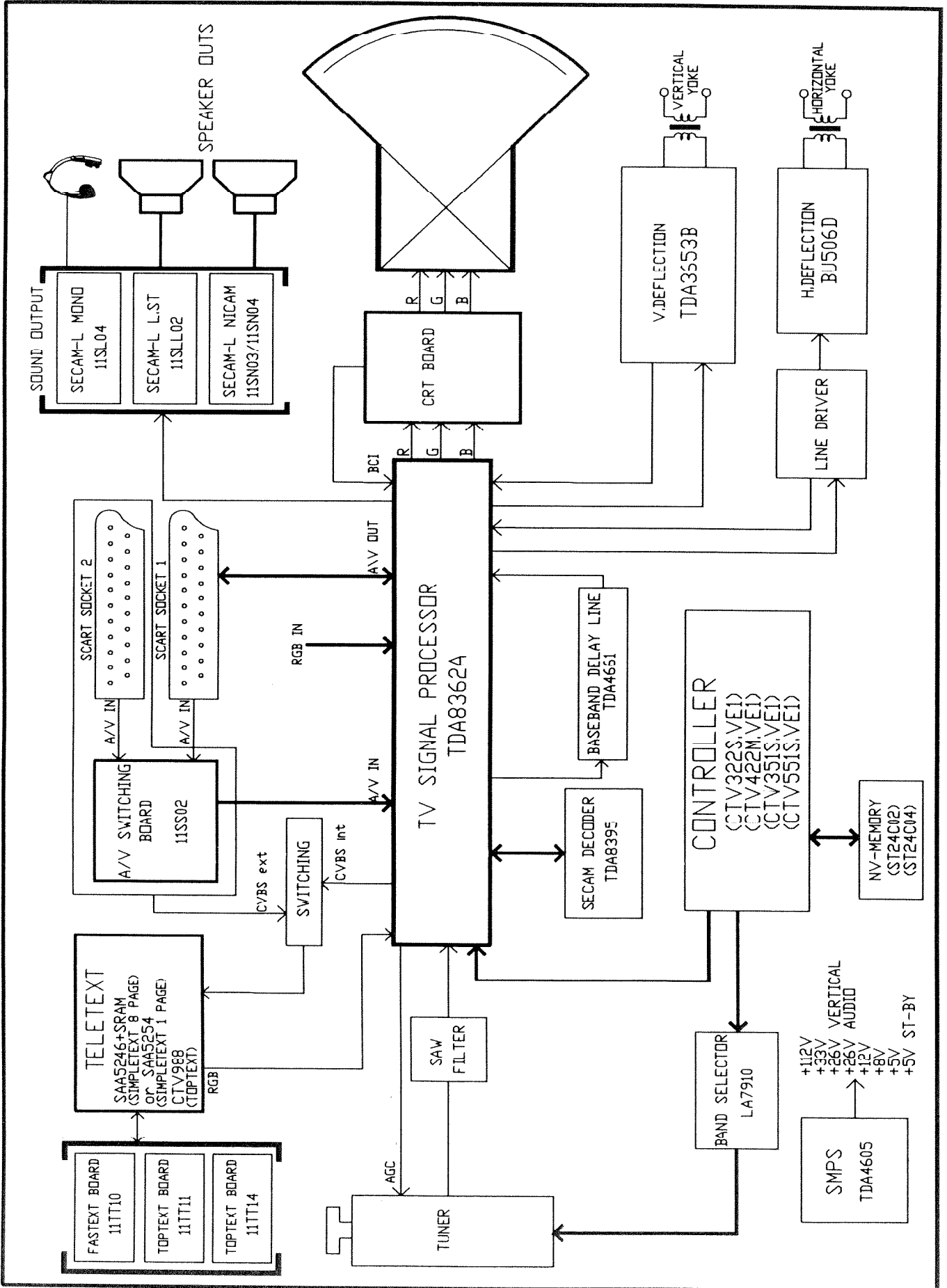

IC DESCRIPTIONS AND INTERNAL BLOCK DIAGRAM

MAIN BOARD	PAGE NO
● TDA8362A	14-15
● TDA4661	16
● ST24C02	17
● TDA3653B	18
● TDA4605-2	19
● FCB61C65	20-21
● PCA84C841 (CTV 422M)	22-24
● PCA84C841 (CTV 351S)	25-27
● PCA84C841 (CTV 322S, CTV222S)	28-30
● LA7910	31
SOUND BOARD	
● TD2546A	32
● TDA1521A	33
● TDA7283	34-35
● TDA8425/V7	36
● TDA2611A	37
TELETEXT BOARD	
● PCF84C81AP/146 (CTV 974)	38-39

TDA8362A

MONOLYTHIC INTEGRATED PAL / NTSC TV PROCESSOR

GENERAL DESCRIPTION : The TDA8362A is nearly identical to the TDA8362. The main difference between the 2 devices is that the TDA8362A contains a black-current stabilisation circuit. Because of the required input pin for the black-current stabilisation circuit the luminance peaking function has been omitted in the TDA8362A. All other functions of the 2 IC's are identical.

FEATURES :

- Multi-standard vision IF amplifier suitable for negative and positive modulation.
- Multi-standard FM sound demodulator (4.5MHz to 6.5MHz).
- Source selection for external A/V inputs (seperate Y/C signals can also be applied).
- Integrated chroma trap and bandpass filters (autocalibrated).
- Luminance delay line integrated.
- Alignment-free PAL/NTSC decoder with automatic search system.
- Easy interfacing with the TDA8395 (SECAM decoder) for multi-standard applications.
- RGB-control circuit with linear RGB inputs and fast blanking.
- Black-current stabilisation circuit.
- Horizontal synchronisation with two control loops and alignment-free horizontal oscillator without external components.
- Vertical count-down circuit (50/60Hz) and vertical preamplifier.
- Low dissipation (only 700mW).
- Only one adjustment (vision IF demodulator).

PINNING

PIN VOLTAGE

1- Audio deemphasis and +/- mod. switch.....	: 3V
2- IF-demodulator tuned circuit.....	: 6V
3- IF-demodulator tuned circuit.....	: 6V
4- Video identification output.....	: 5V
5- Sound IF plus volume control.....	: 0.5V - 4V
6- External audio input.....	: 4V
7- IF video output.....	: 3.25V
8- Decoupling digital supply.....	: 1.8V
9- AFC output.....	: -
10- Positive supply (8V).....	: 8V
11- Ground.....	: -
12- Decoupling filter tuning.....	: 3.25V
13- Internal CVBS input.....	: 4.25V
14- Black-current input.....	: 4V
15- External CVBS input.....	: 3.5V
16- Chroma + A/V switch input.....	: 0V (TV) - 8V (AV)
17- Brightness control input.....	: 1V - 3.5V
18- B-output.....	: 2.5V - 3.5V
19- G-output.....	: 2.5V - 3.5V
20- R-output.....	: 2.5V - 3.5V
21- RGB-insertion and blanking.....	: -
22- R-input for insertion.....	: 3.3V
23- G-input for insertion.....	: 3.3V
24- B-input for insertion.....	: 3.3V
25- Contrast control input.....	: 0V - 3V
26- Saturation control input.....	: 0V - 3V
27- Hue control input (or chroma out).....	: 6V
28- B-Y input signal.....	: 4V
29- R-Y input signal.....	: 4V
30- R-Y output signal.....	: 1.5V
31- B-Y output signal.....	: 1.5V
32- 4.43MHz output for TDA8395.....	: 1.6V (PAL) 4.5V (SECAM)
33- Loop filter burst phase detector.....	: 4.5V
34- 3.58MHz X-tal connection.....	: 3V
35- 4.43MHz X-tal connection.....	: 2V
36- Start horizontal oscillator.....	: 8V
37- Horizontal output.....	: 0.6Vp-p 15.6 KHz
38- Flyback input / sandcastle output.....	: -

39- G2 loop filter	3V
40- G1 loop filter	3.75V
41- Ground	-
42- Vertical feedback input.....	2.5V
43- Vertical ramp generator	2.5V
44- Vertical output	2.5V
45- IF-input.....	4V
46- IF-input.....	4V
47- Tuner AGC output.....	-
48- AGC decoupling capacitor.....	4V
49- Tuner take-over adjustment	-
50- Audio output	3.4V
51- Decoupling sound demodulator	4.5V
52- Decoupling bandgap supply.....	6.5V

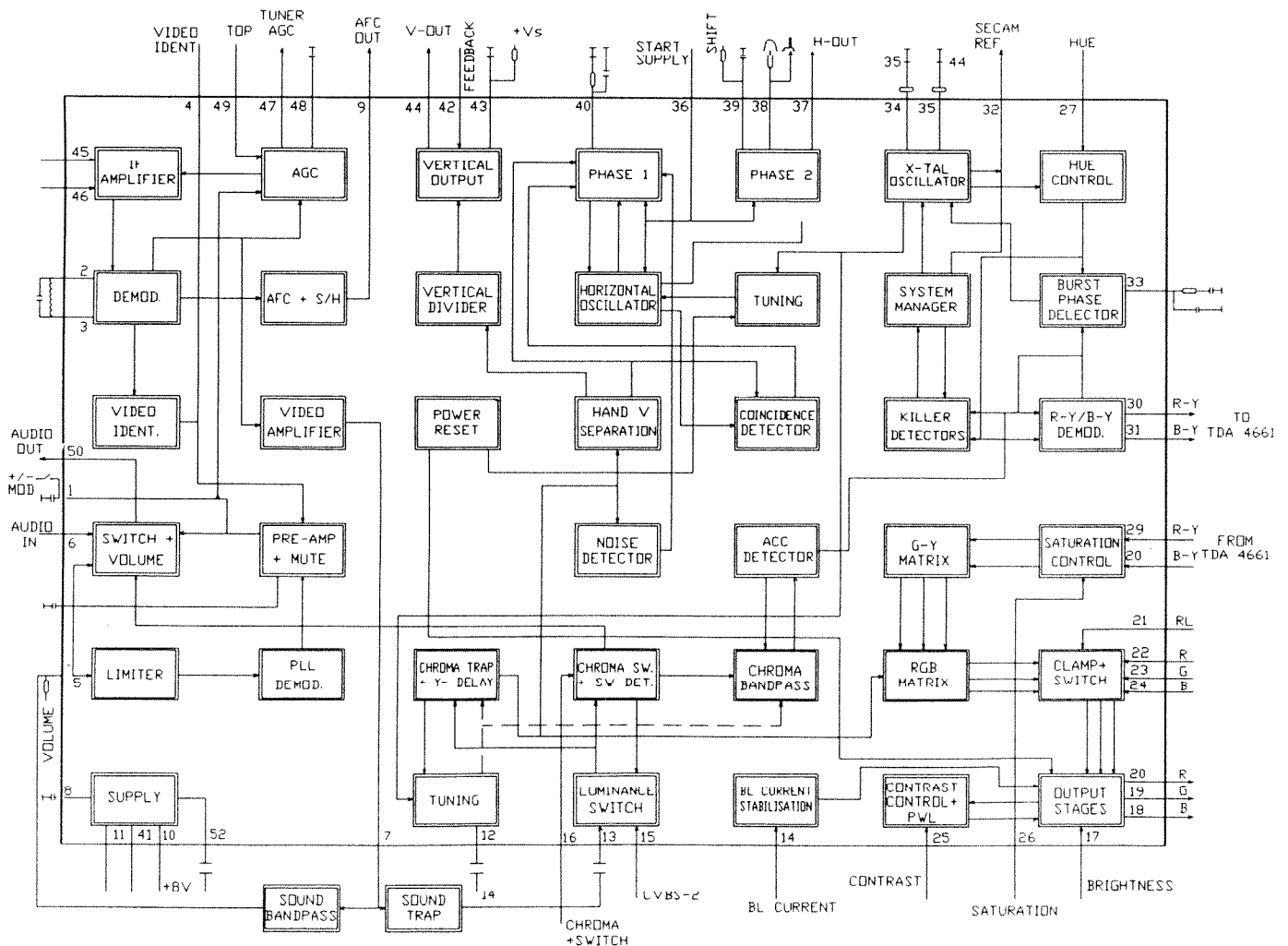

BLOCK DIAGRAM OF TDA8362A

TDA4661

64 micro-second BASEBAND DELAY LINE

GENERAL DESCRIPTION: The TDA4661 is an integrated baseband delay line circuit. It provides a delay of 64 μ s for the colour difference signals. (R-Y) and (B-Y), in multi-standard TVs. The colour difference signals are AC-coupled to pins 16 to 14 respectively and clamped at the input stages. The signals are then fed via buffers to the delay line circuit. The delay line circuit is driven by a 3MHz internal clock which enables the circuit to produce the required delay of 64 μ s. The outputs from the delay line circuit are fed through sample-and-hold and low-pass filters to suppress the clock signal. The delayed and non-delayed are then added and fed to the output pins, 11 and 12, via buffers. The internal clock is derived from a 6MHz voltage controlled oscillator (VCO) which is line-locked via a PLL to the sandcastle pulse at pin 5.

FEATURES :

- Two comp filters using the switched-capacitor technique and with delay time of 64 μ s.
- Generation of a 3MHz internal clock that is line-locked via the sandcastle pulse.

PINNING

PIN VOLTAGE

1- Digital supply voltage.....	5V
2- Not connected.....	-
3- Digital ground.....	-
4- Test input.....	-
5- Sandcastle input.....	-
6- Not connected.....	-
7- Test input.....	-
8- Test input.....	-
9- Analog supply voltage.....	-
10- Analog ground.....	-
11- -(R-Y) output.....	3.25V
12- -(B-Y) output.....	3.25V
13- Reference current.....	-
14- -(B-Y) input.....	1.35V
15- Not connected.....	-
16- -(R-Y) input.....	1.35V

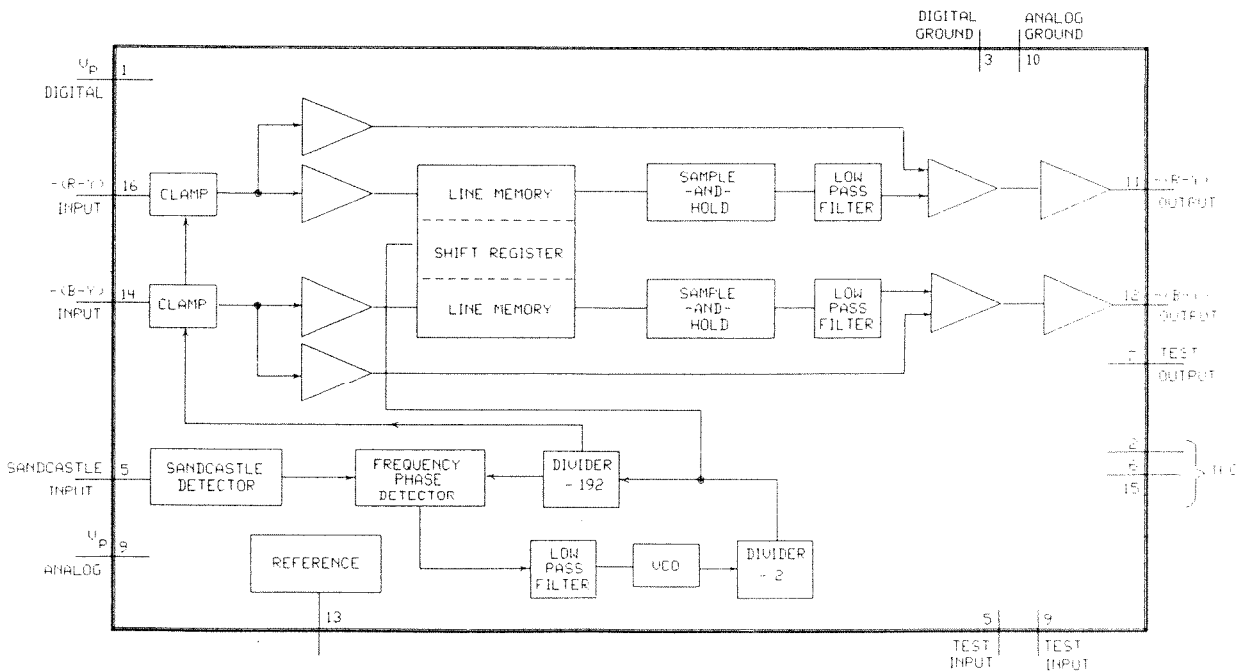

BLOCK DIAGRAM OF TDA4661

ST24C02

2K CMOS Serial Electrically Erasable PROM

GENERAL DESCRIPTION: The 24LC02B is 2K bit Electrically Erasable PROM. The device is organized as a single block of 128x8-bit or 256x3-bit memory with a two wire serial interface. Low voltage design permits operation down to 2.5 volts with a standby and active currents of only 5mA and 1mA respectively. The 24LC02B also has page-write capability for up to 8 bytes of data.

FEATURES :

- Single supply with operation down to 2.5 Volts
- Low power CMOS technology
 - 1mA active current typical
 - 10mA standby current typical at 5.5V
 - 5mA standby current typical at 3.0V
- Organized as a single block of 128 bytes (128x8) or 256 bytes (256x8)
- Two wire serial interface bus
- 100KHz and 400KHz compatibility
- Self-timed write cycle (including auto-erase)
- Page-write buffer for up to 8 bytes
- 2μs typical write cycle time for page-write
- Hardware write protect for entire memory
- Can be operated as a serial ROM
- Factory programming (OTP) available
- ESD protection > 4.000V
- 1.000.000 ERASE/WRITE cycles (typical)
- Data retention > 40 years
- 8-pin DIP or SOIC package
- Available for extended temperature ranges
 - Commercial : 0°C to + 70°C
 - Industrial : -40°C to + 85°C

PINNING

PIN VOLTAGE

- | | |
|-------------------------------------|------|
| 1. 90 Program..... | : 5V |
| 2. No Connection | : 0V |
| 3. No Connection | : 0V |
| 4. Ground | : 0V |
| 5. Serial Address/Data I/O..... | : 5V |
| 6. Serial Clock..... | : 5V |
| 7. Write protect input..... | : 5V |
| 8. +2,5V to 5.5V Power supply | : 5V |

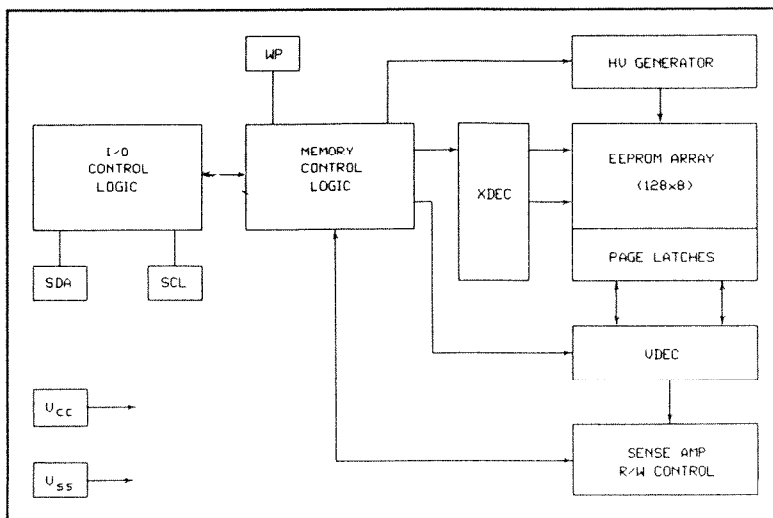

BLOCK DIAGRAM OF ST24C02

TDA3653B

VERTICAL DEFLECTION AND GUARD CIRCUIT

GENERAL DESCRIPTION: The TDA 3653B is a vertical deflection output circuit for drive of various deflection systems with currents up to 1.5 A peak-to-peak.

FEATURES:

- Driver
- Output stage
- Thermal protection and output stage protection
- Flyback generator
- Voltage stabilizer
- Guard circuit

PINNING

PIN VOLTAGE

1. Output Stage Driver Input.....	: 1.2V
2. Ground.....	: -
3. Switching Circuit Input.....	: 1.2V
4. Output Stage Ground.....	: -
5. Output Voltage.....	: 13V
6. Supply Voltage for the Output Stage.....	: 26V
7. DC Voltage produced by the Guard Circuit.....	: -
8. Flyback Generator Output.....	: 8V
9. Supply Voltage.....	: 26V

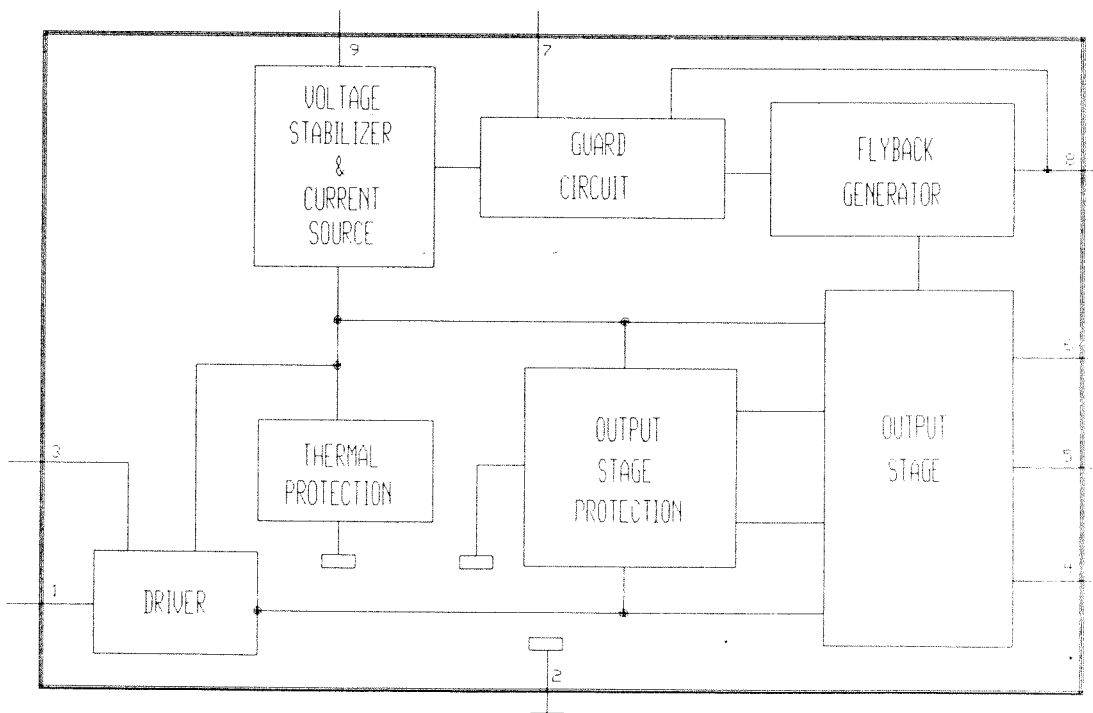

BLOCK DIAGRAM OF TDA3653B

TDA4605-2

SWITCH MODE POWER SUPPLY CONTROLLER

GENERAL DESCRIPTION: The TDA4605-2 is an integrated circuit designed to regulate and control the power mosfet of a switching power supply. Because of its wide operational range and high voltage stability even at high load changes, this IC can be used not only in TV receivers and video recorders but also in power supplies. HI-FI set and active speakers.

FEATURES:

- Fold-back characteristics provides overload protection for external components.
- Burst operation under secondary short-circuit condition implemented.
- Protection against open or a short of the control loop.
- Switch-off line voltage is too low (undervoltage switch-off).
- Line voltage depending compensation of foldback point.
- Soft-start for quite start-up without noise generated by the transformer.
- Chip over-temperature protection (thermal shutdown).
- On-chip ringing suppression circuit against parasitic oscillations of the transformer.

PINNING

PIN VOLTAGE ST-BY NORM.

1. Information Input Concerning Secondary Voltage.....	0.4	0.4
2. Information Input Regarding the Primary Current.....	1	1.2
3. Input for Primary Voltage Monitor.....	2.1	2
4. Ground.....	0	0
5. Output.....	0.8	8
6. Supply voltage Input.....	12	12.8
7. Input for Soft-Start and Integrator Circuit.....	1.1	1.9
8. Input for the Feedback of the Oscillatore.....	0.3	0.4

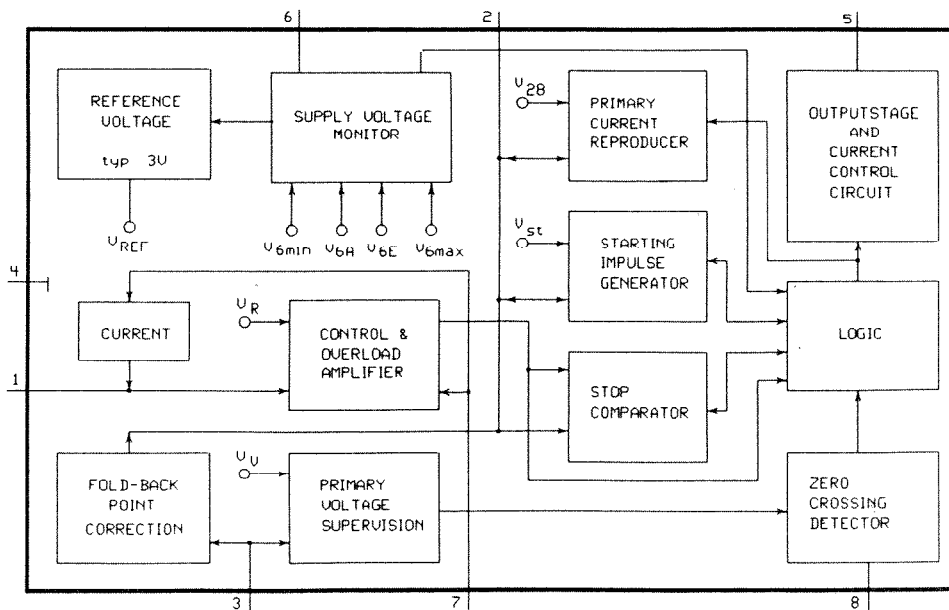

BLOCK DIAGRAM OF TDA4605-2

FCB61C65

8K x 8 FAST CMOS LOW - POWER STATIC RAM

GENERAL DESCRIPTION: The FCB61C65 is a 65536-bit fast, low-power, static random access memory organized as 8192 words of 8 bits each. The chip enable inputs CE1 and CE2 are available for memory expansion and to control the low-power / stand-by mode. The device operates from a 5 V power supply and has an access time of 55 ns and 70 ns. The FCB61C65 is ideally suited for memory applications where fast access time, low power and ease of use are required. The FCB61C65 is a CMOS device which uses a 6 transistor memory cell.

FEATURES:

- Operating supply voltage
- Inputs and outputs ESD protected
- Automatic power-down after a completed read access
- Access time: 55 ns and 70 ns
- Low current consumption:
- Suitable for battery back-up
- Latched data outputs giving stable data between consecutive accesses
- Easy memory expansion
- Common data I/O interface
- All inputs and outputs TTL and CMOS compatible
- All inputs have a Schmitt trigger switching action
- Three-state outputs
- Operating temperature 0 °C to +70 °C

PINNING

PIN VOLTAGE

1. Not Connected.....	:	-
2. Address Input A12.....	:	-
3. Address Input A7.....	:	-
4. Address Input A6.....	:	-
5. Address Input A5.....	:	-
6. Address Input A4.....	:	-
7. Address Input A3.....	:	-
8. Address Input A2.....	:	-
9. Address Input A1.....	:	-
10. Address Input A0.....	:	-
11. Data I/O 1.....	:	-
12. Data I/O 2.....	:	-
13. Data I/O 3.....	:	-
14. Ground.....	:	-
15. Data I/O 4.....	:	-
16. Data I/O 5.....	:	-
17. Data I/O 6.....	:	-
18. Data I/O 7.....	:	-
19. Data I/O 8.....	:	-
20. Chip Enable 1 (CE1).....	:	-
21. Address Input 10.....	:	-
22. Output Enable (OE).....	:	-
23. Address Input A11.....	:	-
24. Address Input A9.....	:	-
25. Address Input A8.....	:	-
26. Chip Enable 2 (CE2).....	:	-
27. Write Enable (WE).....	:	-
28. +5V Supply.....	:	-

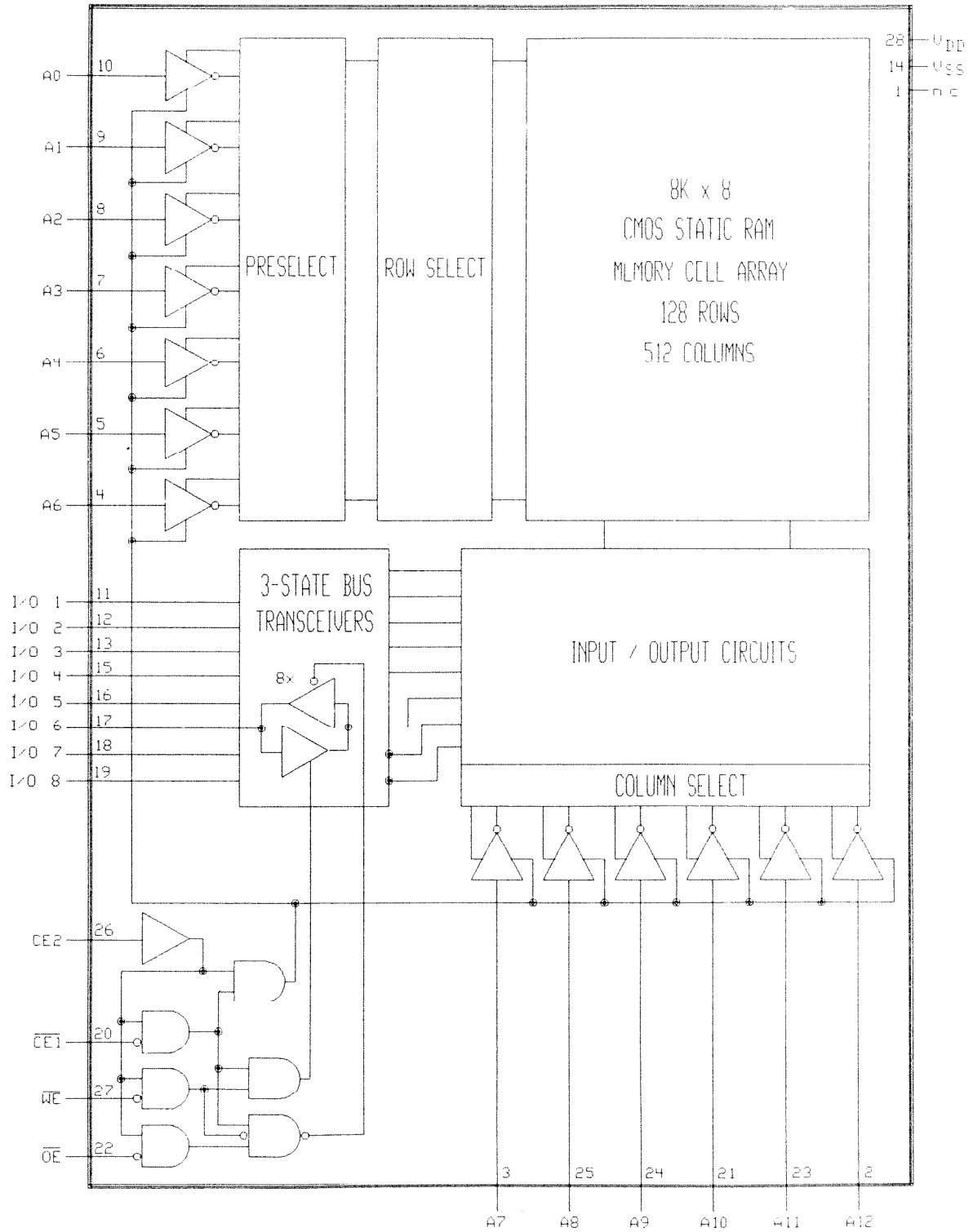

BLOCK DIAGRAM OF PCB61C65

PCA84C841

MICROCONTROLLERS FOR CTV 422M

GENERAL DESCRIPTION: CTV422M is a low cost television receiver control system, based on the PCA84C841 microcontroller. It is a voltage synthesis tuning (VST) system.

The control functions of the system are displayed via the on-screen display circuitry of the microcontroller. Herewith two independent lines of 16 characters with 4 different sizes and in 7 different colour can be displayed. Sound and picture are controlled by the 5 on-chip digital to analogue converters. This system is colour standard independent.

The PCA84C841 is a member of the MAB8400/PCF84C microcontroller family. It is a one-chip microcontroller with an 8-bit CPU, 8K ROM, 192 bytes RAM, 8-bit timer/event counter and single level, 3-source interrupt structure. It is mounted in a 42 pin shrunk DIL package. Manufactured in CMOS technology and operating from a single supply voltage between 3.5V and 5.5V, it runs at a 10MHz oscillation frequency and contains about 80 single and double byte and cycle instruction. Up to 19 general purpose bidirectional I/O lines and 9 I/O lines with a combined function are available. One 8-bit I/O port can sink up to 10mA and can therefore be used to drive directly a LED display.

FEATURES :

TUNING;

- Voltage synthesis tuning system via 14 bits digital to analogue convertor.
- Automatic search tuning based on analogue AFC signal and on IDENT (Video recognition) signal.
- Tuning in up to 4 different bands.
- Manuel search tuning.
- Direct program number entry.
- One and two program number entry.
- Step program up and down.
- Silent tuning.
- Dark program switching.
- Automatic following per program.

CONTROL;

- Up to 28 local control commands.
- Remote control according the RC-5 world standart.

DISPLAY;

Off-screen LED display of stand-by mode.

On-screen display of :

- Menu operations.
- Remote control command reception.
- Two digit program number entry.
- Selected tuner band VHF-1, VHF-3, UHF and VHF-Hyper.
- Analogue tuning bar in search mode and manual/fine tuning.
- Selected external source.
- Store program mode.
- VRT time constand status.
- Selected colour standard mode.
- Sound mute.
- Analogue control mode: volume, brightness, saturation, contrast, and hue.
- Analogue control status bars.
- Selected sleep timer.
- Preduction Service Mode.

SOUND ;

- Volume control in 64 steps (8 steps/second).
- Mono only configuration.
- Mute control function.
- Automatic sound muting during tuning or program switching.

VIDEO ;

- Control of brightness, saturation, contrast and hue in 64 steps (8 steps/second).
- Colour standard control of two different standards.
- VTR time constant control.
- Additional three button control possibility for all analogue colour and sound controls.

PERI-TV ;

- Peripheral source selection via program up/down commands.
- Full peripheral TV plug signal switching: CVBS out, CVBS/RGB in, sound in and out.

MEMORY ;

- Automatic storage of preferred analogue picture and sound control setting.
- Storage of 40 or 90 preferred programs.
- Storage of 14 bit tuning DAC value, band select, system standard, following enable and VTR time constant control bits for each program.
- Storage VTR time constant system selection for peripheral audio/video source.

OPTIONS ;

- Three band, four band or UHF-only tuner.
- Different tuner and AFC characteristics.
- Peripheral audio/video TV plug control.
- Signal/Dual system standard control.
- VTR time constant control.
- 40 or 90 pre-programmed preferred channels, requiring 128 bytes or 256 bytes of NV = memory.
- AC mains supply control via solenoid on mains switch.
- Analogue control of hue.
- On Screen Display in symbols or text strings with or without background.

POWER-ON ;

- Main switch sense input to check whether TV has to be switched-on or to standby mode.
- The program provides a fixed delay of 1.2 seconds and screen blanking about 100 msec to allow to switch-mode power-supply to stabilize.
- After power-on reset of the microcontroller and first time switching-on of the set, the system tunes to program 1 and recalls analogue picture and sound control presets from non-volatile memory.

STANDBY ;

- Sleep timer selection of 15, 30, 45, up to 120 minutes.
- Automatic switching to standby mode when the system is in front-end mode and during the last five minutes no valid input signal is received or no valid remote or local control command is detected. (All complete received commands with system address 00, except the "RC-5 enlarged" commands, will restart the 5 minutes timer. All these commands will also result in an OSD message).
- With additional hardware it is possible to switch off the mains supply voltage completely, e.g. via a solenoid

PRODUCTION SERVICE MODE :

- CTV422M VE1 has been provided with a special production Service Mode which disables the automatic switch off after 5 minutes if mode IDENT is available. This mode can be activated using RC-5 command O with system address 7. Program numbers and peripheral audio/video source designators will appear in green instead of yellow. This mode is implemented particularly for factory burn-in tests..

TELETEXT (These functions only for CTV422M) :

- Either : a 1 page teletext control system by means of SAA5254. All normal teletext function are available. A special signal for de-interlace purposes is available on a single output pin.
- Or : a 4 page teletext control system with SAA5246. All normal teletext functions are available. Also here a special signal for de-interlace purposes is available on a single output pin.

PINNING

1- Tuning voltage control output.....	5V(Front of band) 0V (End of band)
2- Volume control output.....	0 - 5V
3- Brightness control output.....	0 - 5V
4- Colour control output.....	0 - 5V
5- Contrast or hue control output.....	0 - 5V
6- Tone, balance or hue control output.....	-
7- Band-switch 0-output.....	-
8- Band-switch 1 output.....	-
9- Analogue AFC sense input.....	2-4V
10- Dual/Non Dual language sound input.....	-
11- VTR time constand control output.....	-
12- Ext./int. audio/video source control output.....	5V (TV) - 0V (AV)
13- Keyboard scan line input/output.....	-
14- Keyboard scan line input/output.....	-
15- Keyboard scan line input/output.....	-
16- Keyboard scan line input/output.....	-
17- Keyboard scan line input/output.....	-
18- Keyboard scan line input/output.....	-
19- Keyboard scan line input/output.....	-
20- System mode strobe output.....	5V
21- Ground supply input.....	-
22- OSD red output.....	-
23- OSD green output.....	-
24- OSD blue output.....	-
25- OSD fast blanking output.....	-
26- Horizontal synchronization input.....	-
27- Vertical synchronization input.....	-
28- LC oscillator input for OSD.....	5V
29- LC oscillator output for OSD.....	5V
30- Test input; connected to ground.....	-
31- Oscillator input; 10MHz crystal.....	-
32- Oscillator output.....	2V
33- Power-on reset input/output.....	5V
34- Horizontal coincidence input.....	4.5V
35- RC-5 remote control input.....	4V
36- Mono/Stereo or language 1/2 output.....	-
37- Sound effect control output.....	-
38- System select output.....	-
39- I ² C-bus clock signal output.....	5V
40- I ² C-bus data signal output.....	5V
41- Standby/On control input/output.....	0V (ST-BY) - 5V (OPEN)
42- +5V supply voltage input.....	5V

PIN VOLTAGE

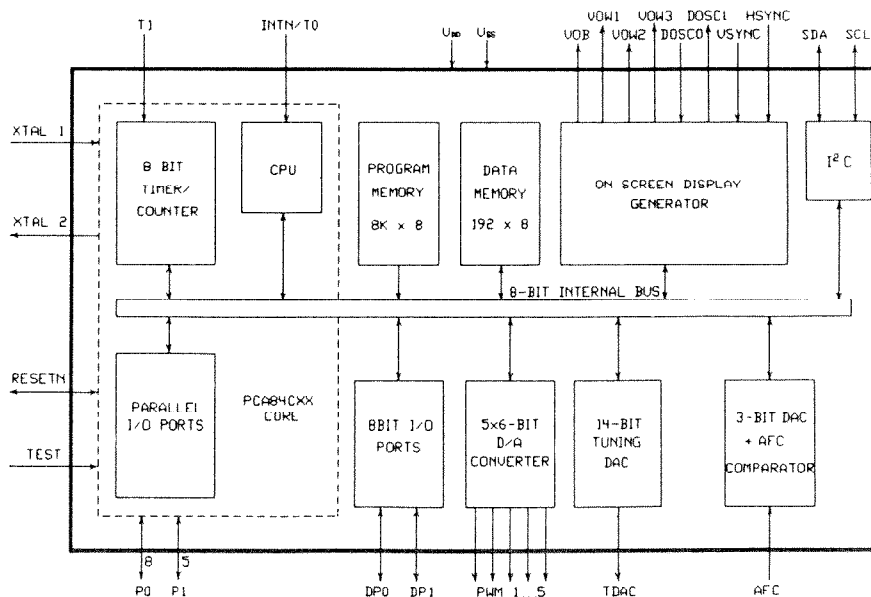

BLOCK DIAGRAM OF PCA84C841

PCA84C841

MICROCONTROLLERS FOR CTV 351S

GENERAL DESCRIPTION: CTV351S is a low cost television receiver control system, based on the PCA84C841 microcontroller. It is a voltage synthesis tuning (VST) system with on-screen-display (OSD) of all relevant control function. Analogue picture settings are controlled by 4 on-chip digital to analogue convertors. Sound volume can be controlled by the fifty on-chip digital to analogue convertor in a mono-only system. Full sound (Volume, Bass, Treble, Balance) can be controlled via the I²C-bus in a German Stereo and/or Nicam configuration, using a Hi-Fi sound audio processor.

CTV351S can control up to two SCART plugs and an S-VHS plug.

The system is colour standard independent and can be used all over the world. It can select 3 system (PAL, SECAM and NTSC) and has additional options for sound systems.

The system fulfils numerous and varied requirements and has options to make it applicable to all markets.

The PCA84C841 is a member of the MAB8400/PCF84C00 microcontroller family. It is a one-chip microcontroller with an 8-bit CPU, 8K ROM, 192 bytes RAM, 8-bit timer/event counter and single level, 3-source interrupt structure. It is mounted in a 42 pin shrunk DIL package. Manufactured in CMOS technology and operating from a single supply voltage between 3.5V and 5.5V, it runs at a oscillation frequencies up to 10MHz and contains about 80 single and double byte and cycle instruction. Up to 17 general purpose bidirectional I/O lines and 11 I/O lines with a combined function are available. One 8-bit I/O port can sink up to 10mA and can therefore be used to drive directly a LED display.

FEATURES :

TUNING;

- Voltage synthesis tuning system via 14 bits digital to analogue convertor.
- Automatic search tuning based on analogue AFC signal and on IDENT (Video recognition) signal.
- Tuning in up to 4 different bands.
- Manual search tuning.
- Direct program number entry.
- One and two program number entry.
- Step program up and down.
- Last-tuned programme registration and swap function.
- Silent tuning.
- Dark program switching.
- Automatic following per program.

CONTROL:

- Up to 28 local control commands.
- Remote control according the RC-5 world standart.

DISPLAY:

Off-screen LED display of stand-by mode.

On-screen display of :

- Menu operations.
- Remote control command reception.
- Selected source (Programme, AV-1, AV-2, GRB, AV-S).
- Selected sound mode (MONO, DUAL-I, DUAL-II, STEREO).
- One or two digit programme number entry. (-/-).
- Selected tuner band VHF-1, VHF-3, UHF and VHF-Hyper.
- Selected system (SYS-1, SYS-2).
- Analogue tuning bar in search mode.
- Store and clear programme mode.
- Sound mute.
- Analogue control; recall, store and clear preferred settings.
- Analogue control of; volume, brightness, colour, contrast, hue, balance, treble, bass.
- Analogue control status bars.
- Selected sleep timer.

SOUND ;

- Volume control.
- Optional balance, treble and bass control.
- Mute control function.
- Automatic sound muting during tuning.
- Automatic sound muting during program switching.
- Optional German Stereo sound decoding.
- Optional Nicam Sound decoding

VIDEO ;

- Control of brightness, colour, contrast and hue in 64 steps (8 steps/second).
- System standart control of two different standards.
- Additional three button control possibility for all analogue colour and sound controls.

PERI-TV ;

- Peripheral Tv plug signal switching. Two SCART plugs and S-VHS plugs are supported. Up to four peri sources can be selected (CVBS on SCART-1, RGB on SCART-1, CVBS on SCART-II and S-VHS). For all peri sources full sound switching is optionally available.
Automatic switching to CVBS on SCART-I. Any source (Peripheral or front-end) except CVBS on SCART-I can be overruled by auto cvbs switching.

MEMORY ;

- Storage of 40 or 90 preferred programmes.
- Storage of 14 bit tuning DAC value, band select, system standard, dual language preference and automatic following enable control bits for each programme.
- Storage of preferred analogue picture and sound control settings.
- Storage of system standard and sound mode selection for for peripheral audio/video sources.

OPTIONS ;

- Three band, four band or UHF-only tuner.
- Different tuner and AFC characteristics.
- Peripheral audio/video TV plug control.
- System control.
- German Stereo and/or Nicam or mono-only sound control.
- 40 or 90 pre-programmed preferred channels. (128 or 256 bytes of NV-memory).
- One page, four page or high performance teletext.
- OSD text or symbols with or without background.
- Remote fine tuning.
- Analogue control of hue.
- Remote control commands search, store, fine tuning and system standard select anabled or disabled.

POWER-ON ;

- Main switch sense input to check whether TV has to be switched-on or to standby mode.
- The program provides a fixed delay of 1.2 seconds and screen blanking about 100msec to allow the switch-mode power-supply to stabilize.
- After power-on reset of the microcontroller and first time switching on of the set, the system tunes to the first available valid programme and recalls analogue picture and sound control presets from non-volatile memory. If all programmes are "cleared" the programme number is forced to 1 anyway.

STANDBY ;

- Standby command.
- Sleep timer expiration after 15, 30, 45, up to 120 minutes.
- Automatic switching to standby mode when the system is in front-end mode and during the last 5 munites no valid input signal is received or no valid remote or local control command is detected.
- Switching on witout the third momentary contact on the mains switch.

PRODUCTION SERVICE MODE :

- CTV351S is equipped with a special Production Servive Mode, in order to prevent the set from switching of after 5 minutes if no IDENT is present. This mode is veryuseful during factory burn-in trsts..

TELETEXT (These functions only for CTV351S) :

- Either: a single page teletext control system by means of SAA5254. All normal teletext function are available. A special signal for de-interlace purposes is available on the odd/even output of the SAA5244.
- Or : a 4 page teletext control system with SAA5246 and an 8k8 SRAM. All normal teletext functions are available. A special signal for de-interlance purposes is available on the odd/even pin of the SAA5246.
- Or : Control of additional special teletext features like FASTEXT, TOP, LIST, packet X/26 (for Spain and Eastern Europe), using a second microcontroller containing a teletext software package CTV97xS or CTV99xS.

PINNING

1- Tuning voltage control output	5V(Front of band) 0V (End of band)
2- Volume control output	0 - 5V
3- Brightness control output	0 - 5V
4- Colour control output	0 - 5V
5- Contrast or hue control output	0 - 5V
6- Tone, balance or hue control output.....	-
7- Band-switch 0 output	-
8- Band-switch 1 output	-
9- Analogue AFC sense input	2-4V
10- AV status input	-
11- External source select output.....	-
12- FE/AV select output	5V (TV) - 0V (AV)
13- Keyboard scan line input/output	-
14- Keyboard scan line input/output	-
15- Keyboard scan line input/output	-
16- Keyboard scan line input/output	-
17- Keyboard scan line input/output	-
18- Keyboard scan line input/output	-
19- Keyboard scan line input/output	-
20- System mode strobe output.....	5V
21- Ground supply input.....	-
22- OSD red output.....	-
23- OSD green output.....	-
24- OSD blue output	-
25- OSD fast blanking output	-
26- Horizontal synchronization input	-
27- Vertical synchronization input	-
28- LC oscillator input for OSD	5V
29- LS oscillator output for OSD.....	5V
30- Test input; connected to ground	-
31- Oscillator input; 10MHz crystal.....	-
32- Oscillator output	2V
33- Power-on reset input/output.....	5V
34- Horizontal coincidence input.....	4.5V
35- RC-5 remote control input	4V
36- External source select output.....	-
37- System select output	-
38- System select output	-
39- I ² C-bus clock signal output.....	5V
40- I ² C-bus data signal output	5V
41- Standby/On control input/output.....	0V (ST-BY) - 5V (OPEN)
42- +5V supply voltage input	5V

PIN VOLTAGE

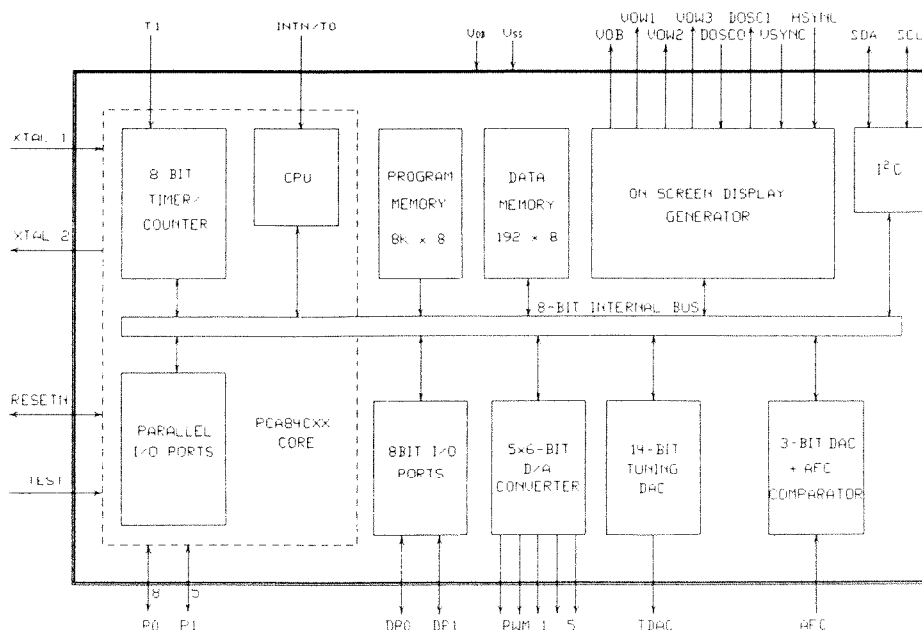

BLOCK DIAGRAM OF PCA84C841

PCA84C641 / PCA84C444

MICROCONTROLLERS FOR CTV 322S (CTV 222S)

GENERAL DESCRIPTION: CTV322S (CTV222S) is a low cost television receiver control system, based on the PCA84C641 (PCA84C444) mikrocontroller. It is a voltage synthesis tuning (VST) system. The control functions of the system are displayed via the on-screen display circuitry of the mikrocontroller. Herewith two independent lines of 16 characters with 4 different sizes and in 7 different colour can be displayed. Sound and picture are controlled by the 5 on-chip digital to analogue converters. This system is colour standard independent.

The PCA84C641-VST is a member of the PCA84CXX CMOS mikrocontroller family. It includes the PCA84C processor core, 6142 bytes of mask-programmable program ROM, 128 bytes of RAM, a multimaster 1 C bus interface, 2 directly testable lines, 17 general purpose bi-directional I/O lines plus 11 function-combined I/O lines, one 14-bit PWM "analog" control, an AFC input (3-bit DAC + comparator) for voltage synthesized tuning (VST), five 6-bit PWM "analog" control outputs, and a display-on-screen (DOS) facility for two lines of 16 characters (max. 64 character types).

The PCA84C444 is a member of the MAB8400/PCF84C mikrocontroller family. It is a one-chip mikrocontroller with an 8-bit CPU, 4K ROM, 128 bytes RAM, 8-bit timer/event counter and single level, 3-source interrupt structure. It is mounted in a 42 pin shrunk DIL package. Manufactured in CMOS technology and operating from a single supply voltage between 3.5V and 5.5V, it runs at a 10MHz oscillation frequency and contains about 80 single and double byte and cycle instruction. Up to 17 general purpose bidirectional I/O lines and 11 I/O lines with a combined function are available. One 8-bit I/O port can sink up to 10mA and can therefore be used to drive directly a LED display.

FEATURES : **TUNING;**

- Voltage synthesis tuning system via 14 bits digital to analogue convertor.
- Automatic search tuning based on analogue AFC signal and on IDENT (Video recognition) signal.
- Tuning in up to 4 different bands.
- Manual search tuning.
- Direct program number entry.
- One and two program number entry.
- Step program up and down.
- Last-tuned program registration and swap function.
- Silent tuning.
- Dark program switching.
- Automatic following per program.

CONTROL;

- Up to 28 local control commands.
- Remote control according the RC-5 world standart.

DISPLAY;

Off-screen LED display of stand-by mode.

On-screen display of :

- Remote control command reception.
- One or two digit program number entry.
- Program sound status line.
- Selected tuner band VHF-1, VHF-3, UHF and VHF-Hyper.
- Analogue tuning bar in search mode and manual/fine tuning.
- Selected external source.
- Store and clear program mode.
- VRT time constant status.
- Selected colour standard mode.
- Sound mute.
- Recall analogue control, store and clear (hard preset) mode.
- Analogue control mode: volume, brightness, colour, contrast, balance, tone, and/or hue.
- Analogue control status bars.
- Selected sleep timer.
- Production Service Mode.

SOUND ;

- Volume control in 64 steps (8 steps/second).
- Optional effect control.
- Mute control function.
- Automatic sound muting during tuning or program switching.

VIDEO ;

- Control of brightness, colour, contrast and hue in 64 steps (8 steps/second).
- Colour standard control of two different standards.
- VTR time constant control.
- Additional three button control possibility for all analogue colour and sound controls.

PERI-TV ;

- Full peripheral TV plug signal switching: CVBS out, CVBS/RGB in, sound in and out.

MEMORY ;

- Storage of preferred analogue picture and sound control setting.
- Storage of 40 or 90 preferred programs.
- Storage of 14 bit tuning DAC value, band select, system standard, dual language selection, following enable and VRT time constant control bits for each program.
- Storage VRT time constant system and dual language selection for peripheral audio/video source.

OPTIONS ;

- Three band, four band or UHF-only tuner.
- Different tuner and AFC characteristics.
- Stereo, dual language or mono sound control.
- Sound affect control.
- Peripheral audio/video TV plug control.
- Signal/Dual system standard control.
- VTR time constant control.
- 40 or 90 pre-programmed preferred channels, requiring 128 bytes or 256 bytes of NV = memory.
- AC mains supply control via solenoid on mains switch.
- Analogue control of hue, contrast, balance and/or tone.
- On Screen Display in symbols or text strings with or without background.
- Four or five analogue controls.

POWER-ON ;

- Main switch sense input to check whether TV has to be switched-on or to standby mode.
- The program provides a fixed delay of 1.2 seconds and screen blanking about 100 msec to allow to switch-mode power-supply to stabilize.
- After power-on reset of the microcontroller and first time switching-on of the set, the system tunes to program 1 and recalls analogue picture and sound control presets from non-volatile memory. If program 1 is "cleared", the system tunes to the first "stored" program. If all programs are "cleared" the program number is forced to 1.

STANDBY ;

- Sleep timer selection of 15, 30, 45, up to 120 minutes.
- Automatic switching to standby mode when the system is in front-end mode and during the last five minutes no valid input signal is received or no valid remote or local control command is detected. (All complete received commands with system address 00, except the "RC-5 enlarged" commands, will restart the 5 minutes timer. All these commands will also result in an OSD message). With additional hardware it is possible to switch off the mains supply voltage completely, e.g. via a solenoid.

TELETEXT (These functions only for CTV322S) :

- Either : a page teletext control system by means of SAA5244. All normal teletext are available. A special signal for de-interlace purposes is available on a single output pin.
- Or : a 4 page teletext control system with SAA5246. All normal teletext functions are available. Also here a special signal for de-interlace purposes is available on a single output pin.
- Or : a 4 page teletext control system by means of the SAA5243 (EECI) + SAA5231 (VIP). All normal teletext functions are available. A special PON (Picture On) signal can be combined with an odd/even signal for de-interlace purposes.

PINNING

1- Tuning voltage control output	: 5V(Front of band) 0V (End of band)
2- Volume control output	: 0 - 5V
3- Brightness control output	: 0 - 5V
4- Colour control output.....	: 0 - 5V
5- Contrast or hue control output	: 0 - 5V
6- Tone, balance or hue control output	: -
7- Band-switch 0 output.....	: -
8- Band-switch 1 output.....	: -
9- Analogue AFC sense input	: 5V
10- Dual/Non Dual language sound input	: -
11- VTR time constand control output.....	: -
12- Ext./int. audio/video source control output	: 5V (TV) - 0V (AV)
13- Keyboard scan line input/output.....	: -
14- Keyboard scan line input/output.....	: -
15- Keyboard scan line input/output.....	: -
16- Keyboard scan line input/output.....	: -
17- Keyboard scan line input/output.....	: -
18- Keyboard scan line input/output.....	: -
19- Keyboard scan line input/output.....	: -
20- System mode strobe output	: 5V
21- Ground supply input	: -
22- OSD red output	: -
23- OSD green output	: -
24- OSD blue output.....	: -
25- OSD fast blanking output	: -
26- Horizontal synchronization input.....	: -
27- Vertical synchronization input.....	: -
28- LC oscillator input for OSD	: 5V
29- LC oscillator output for OSD.....	: 5V
30- Test input; connected to ground	: -
31- Oscillator input; 10MHz crystal	: -
32- Oscillator output	: 2V
33- Power-on reset input/output	: 5V
34- Horizontal coincidence input.....	: 4.5V
35- RC-5 remote control input	: 4V
36- Mono/Stereo or language 1/2 output	: -
37- Sound effect control output	: -
38- System select output.....	: -
39- I ² C-bus clock signal output.....	: 5V
40- I ² C-bus data signal output.....	: 5V
41- Standby/On control input/output	: 0V (ST-BY) - 5V (OPEN)
42- +5V supply voltage input.....	: 5V

PIN VOLTAGE

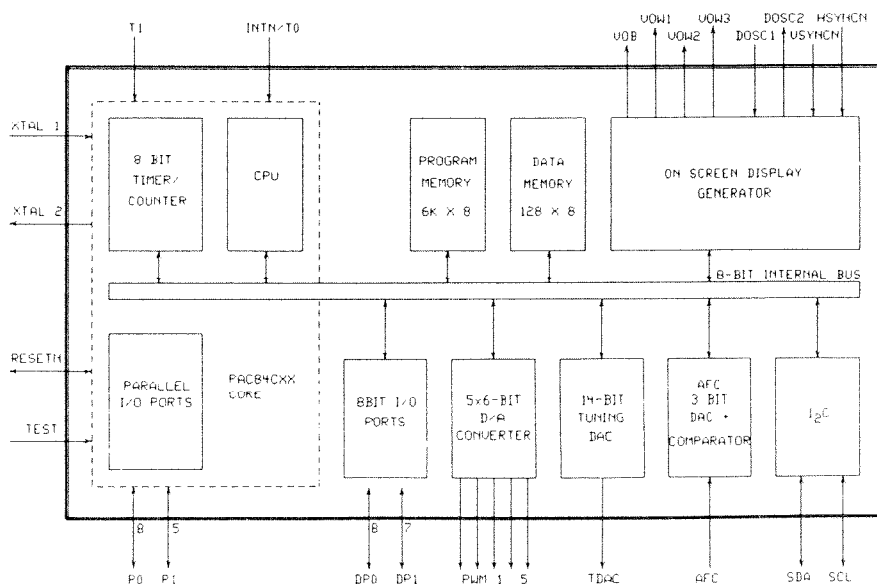

BLOCK DIAGRAM OF PCA84C641

LA7910

TV TUNER BAND SELECTOR

GENERAL DESCRIPTION: The LA7910 is an IC for tuner band selection of electronic tuning type television set. This IC is used for producing the VHF channel "L" band power supply, VHF channel "H" band power supply, UHF channel power supply for tuner and the CATV power supply according to the band select signal of 2 inputs.

FUNCTIONS :

- VHF "L" band power supply output
- VHF "H" band power supply output
- UHF power supply output
- CATV power supply output

FEATURES

- 2 inputs and 4 outputs
- Low output saturation voltage : 0.25V typ., $I_O = 60\text{mA}$
- Compact 9-pin single-end package

PINNING

	PIN VOLTAGE			
	WHF-L	VHF-H	UHF	CATV
1- Output	12	0	0	0
2- Output	0	12	0	0
3- Input	0	1	0	0
4- Input	0	0	1	1
5- Ground	-	-	-	-
6- Supply voltage (18V).....	13.5	13.5	13.5	13.5
7- Output	0	0	12	0
8- Output	0	0	0	12
9- Supply voltage (12V DC).....	12	12	12	12

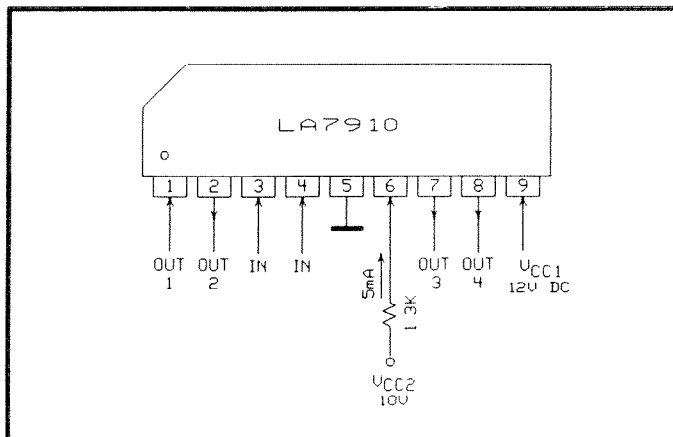

BLOCK DIAGRAM OF LA7910

TDA2546A

5.5 MHz DEMODULATION

GENERAL DESCRIPTION: The TDA2546A is monolithic integrated circuit for quasi-split-sound processing 5.5MHz demodulation, in television receivers.

FEATURES :

1st i.f. (V.C.: vision carrier plus S.C.: sound carrier)

- 3-stage gain controlled i.f. amplifier.
- A.G.C. circuit.
- Reference amplifier and limiter amplifier for vision carrier (V.C.) processing.
- Linear multiplier for quadrature demodulation.

2nd i.f. (5.5MHz signal)

- 8-stage limiter amplifier
- Quadrature demodulator
- A.F. amplifier with de-emphasis
- AV switch

PINNING

PIN VOLTAGE

1. If input 1	:4.8V
2. G-STAB	:4.8V
3. C AGC	:6.15V
4. Muting	:0.6V
5. Af deemphasis.....	:4.77V
6. Af output.....	:4.12V
7. FM demodulator input	:3V
8. FM demodulator output.....	:3V
9. Vision demodulator input	:5.64V
10. Vision demodulator output	:5.64V
11. Reference voltage	:2V
12. FM input	:2V
13. FM reference	:2V
14. Intercorrier output.....	:6.08V
15. Supply voltage.....	:12.52V
16. Ground.....	:0V
17. G-STAP	:4.8V
18. If input 2.....	:4.83V

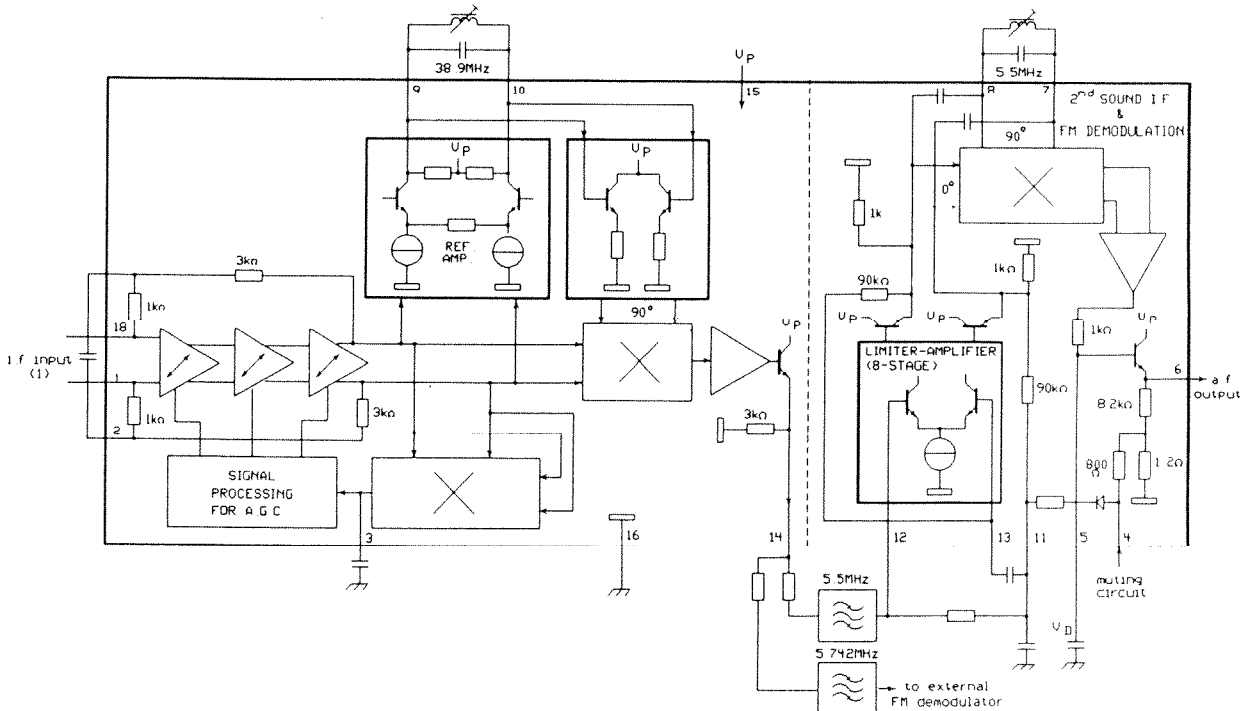

BLOCK DIAGRAM OF TDA2546A

TDA1521A

2 X 6W HI-FI AUDIO POWER AMPLIFIER

GENERAL DESCRIPTION: The TDA1521A is dual hi-fi audio power amplifier encapsulated in a 9-lead plastic power package. The device is especially designed for mains fed applications.

FEATURES :

- Requires very few external components
- Input muted during power-on and off (no switch-on or switch-off clicks)
- Low offset voltage between output and ground
- Excellent gain balance between channels
- Hi-fi according to IEC 268 and DIN 45500
- Short - circuit - proof
- Thermally protected

PINNING

PIN VOLTAGE

1. Non-inverting Input 1.....	:13.5V
2. Inverting Input 1.....	:13.7V
3. Ground.....	:13.6V
4. Output 1.....	:13.7V
5. Negative Supply Voltage.....	:0V
6. Output 2.....	:13.67V
7. Positive Supply Voltage.....	:27.18V
8. Inverting Input 2.....	:13.65V
9. Inverting Input 2.....	:13.4V

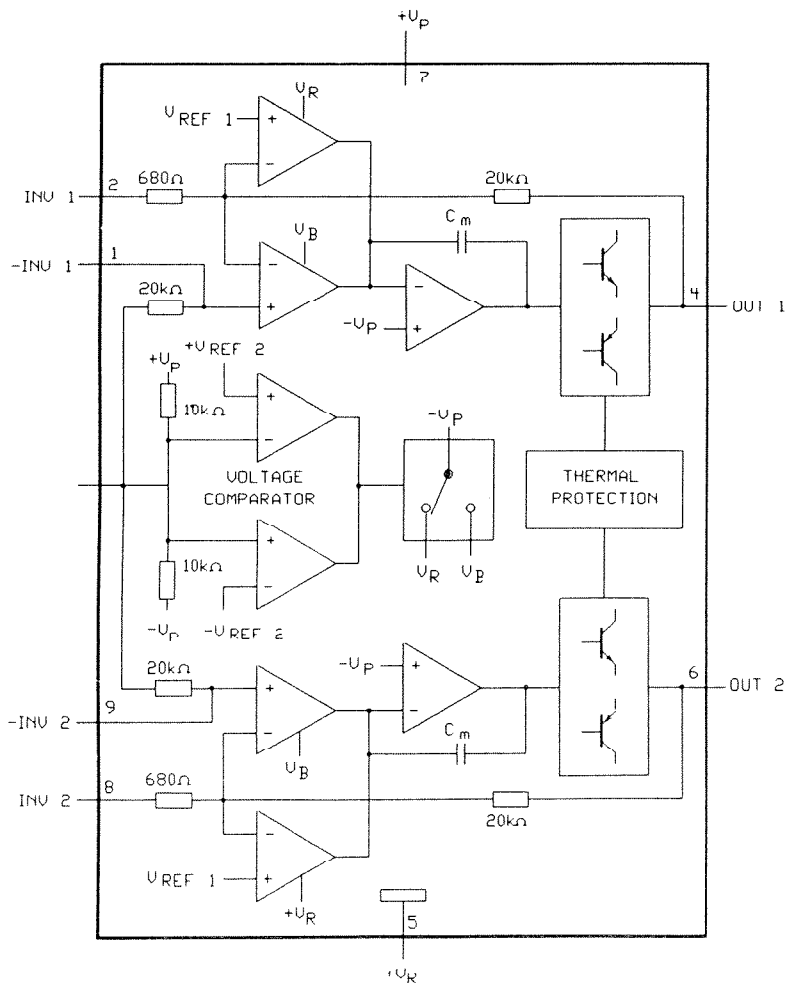

BLOCK DIAGRAM OF TDA1521A

SAA7283

SINGLE CHIP SYSTEM INDEPENDENT NICAM-728 RECEIVER

GENERAL DESCRIPTION: The SAA7283 is a single chip, system independent, NICAM 728 receiver. The DQPSK demodulation and filtering is fully integrated using a high performance analogue process. The digital decoder and digital to analogue sound conversion is performed using proven circuitry from the SAA7282 (TDS2). The SAA7283 offers a reduced component count and operation from a 5 volt supply.

The device contains all of the features offered by the SAA7282, together with some new features. To maintain software compatibility with the SAA7282 the write and read register maps of the SAA7283 have been aligned with the register maps of the SAA7282, with two further registers controlling the additional features being placed at sub-addresses 011 and 100, and one additional status byte. At power-up, the SAA7283 initialises into a fully functional mode of operation.

FEATURES:

- Single chip solution with integrated FM and vision filters, analogue demodulator and audio switching offering significantly reduced component count.
- Single low radiation sinusoidal crystal oscillator for improved EMC
- Dual standard with automatic selection between PAL System I and BGC standards. Automatic selection can be disabled and manual selection made via I²C control
- Improved system performance by increased attenuation of interference components and greater input sensitivity.
- Automatic mute function which switches from NICAM to FM sound (if valid) when error rate exceeds user definable limits
- Power-on silence function. Silence can be set and cleared via I²C control
- Four times oversampling digital filter
- Selectable digital J17 de-emphasis
- Bitstream conversion DACs. Typically 80uB THD&N with an output level of 1Vrms
- Integrated switching networks allowing selection between NICAM sound, FM sound or external "Daisy-Chain" Input
- Digital Audio Interface conforming with EBU/IEC 958, can be enabled and disabled via I²C control
- Programmable attenuator for matching NICAM and FM sources at the output of the device
- NICAM audio level compensation between system BGH and system I
- 5 Volt supply
- Software compatible with SAA7282

PINNING

PIN VOLTAGE

1. Mute input.....	:5V
2. Digital audio interference output	:2.54V
3. Audio VDD.....	:5V
4. Audio VSS	:0V
5. Internal audio reference voltage buffer.....	:2.52V
6. External analogue input (Right).....	:0.33V
7. Fm sound input (Right)	:2.52V
8. Analogue output (Right)	:2.51V
9. Not connected.....	:0V
10. Not connected.....	:0V
11. Internal audio reference voltage buffer output	:2.52V
12. Quiet VSS to DACs.....	:0V
13. Not connected.....	:0V
14. Not connected.....	:0V
15. Analogue audio output (Left)	:2.53V
16. FM sound input (Left)	:2.53V
17. External analogue input (Left).....	:0.4V
18. Power-on reset mute.....	:4.9V
19. Power-on reset audio select.....	:-
20. Carrier loop filter connection.....	:-
21. Carrier loop filter output	:-
22. Sine channel eve pattern output	:-
23. Sine channel offset compensator capacitor.....	:2.50V
24. Demodulator VSS	:0V
25. VCO control voltage input	:2.53V
26. Demodulator VDD.....	:5.83V
27. VCO control voltage input	:5V

28. Mixer voltage reference.....	:2.4V
29. DQPSK input.....	:2.52V
30. Cosine channel offset compensator capacitor.....	:2.51V
31. Cosine channel eye pattern output.....	:2.47V
32. AGC peak detector storage capacitor.....	:2.5V
33. Internal demodulator reference voltage buffered output.....	:2.38V
34. Internal demodulator reference current output.....	:2.51V
35. Internal demodulator reference voltage unbuffered output.....	:2.456V
36. Demodulator VDD.....	:2.5V
37. Demodulator VSS.....	:5V
38. Not connected.....	:0V
39. Clock loop phase comparator output.....	:1.97V
40. 8.192MHz Xtal input.....	:3.11V
41. 8.192MHz Xtal output.....	:2.6V
42. Xtal oscillator VSS.....	:0V
43. Data input (Serial - 728 kbits/s).....	:2.5V
44. Data output (Serial - 728 kbits/s).....	:0V
45. Clock output (728KHz).....	:0.5V
46. Digital VSS.....	:5V
47. Digital VDD.....	:4.7V
48. Data output (Serial - 728 kbits/s).....	:2.5V
49. Clock input (for I ² C).....	:4.4V
50. Data input/output (for I ² C).....	:4.4V
51. I ² C address bit 0 input.....	:0V
52. I ² C bus bit (controlled from PORT2).....	:5V

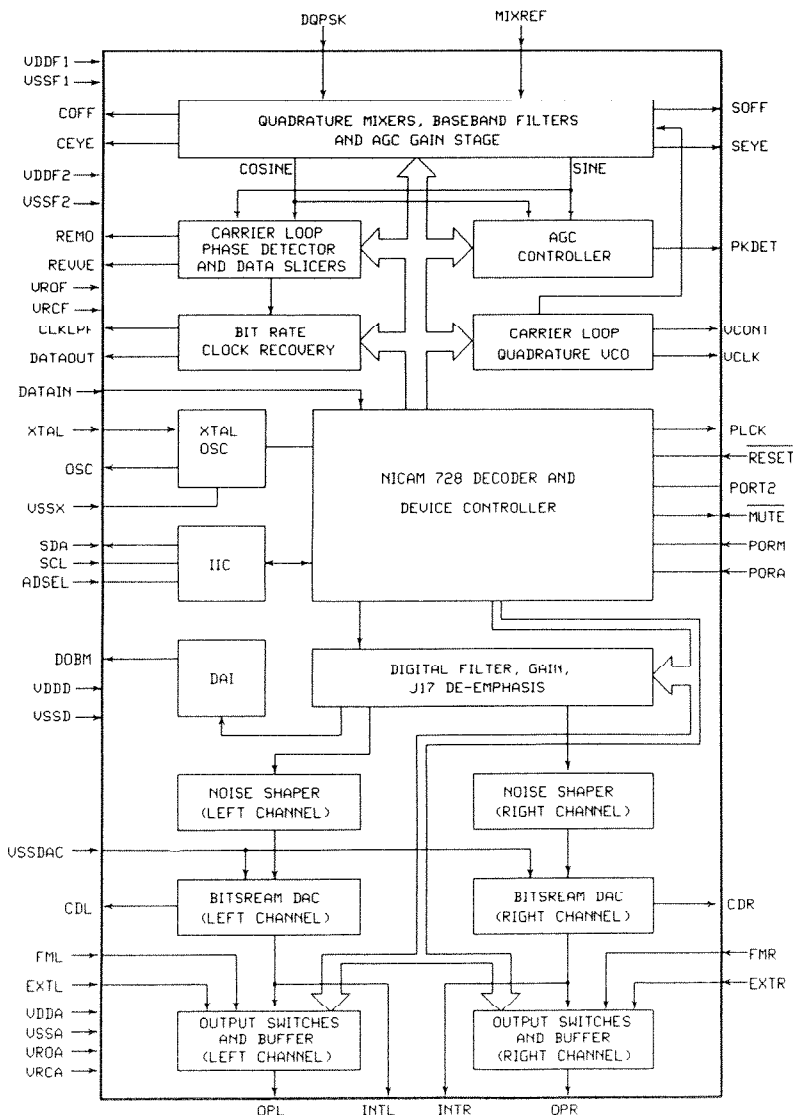

BLOCK DIAGRAM OF SAA7283

TDA8425/V7

HI-FI STEREO AUDIO PROCESSOR; I²C-BUS

GENERAL DESCRIPTION: The TDA8425 is monolithic bipolar integrated stereo sound circuit with a loudspeaker channel facility, digitally controlled via the I²C-bus for application in hi-fi audio and television sound.

FEATURES :

- Source and mode selector for two stereo channels
- Pseudo stereo, spatial stereo, linear stereo and forced mono switch
- Volume and balance control
- Bass, treble and mute controls
- Power supply with power-on reset

PINNING

PIN VOLTAGE

1. Input 2 (Left).....	:5.83V
2. External decouplage capacitor (V _{CAP})	:11.66V
3. Input 2 (Right).....	:5.84V
4. Supply voltage	:11.76V
5. Ground.....	:0V
6. Bass (Right)	:5.84V
7. Bass (Right)	:5.85V
8. Treble (Right).....	:5.85V
9. Output (Right).....	:5.85V
10. Ground	:0V
11. Voltage Range.....	:4.3V
12. Voltage Range.....	:4.3V
13. Output (Left).....	:5.85V
14. Treble (Left).....	:5.85V
15. Bass (Left).....	:5.85V
16. Bass (Left).....	:5.84V
17. External capacitors 2.....	:5.84V
18. Input 1 (Left)	:5.83V
19. External capacitor 1.....	:5.83V
20. Input (Right)	:5.83V

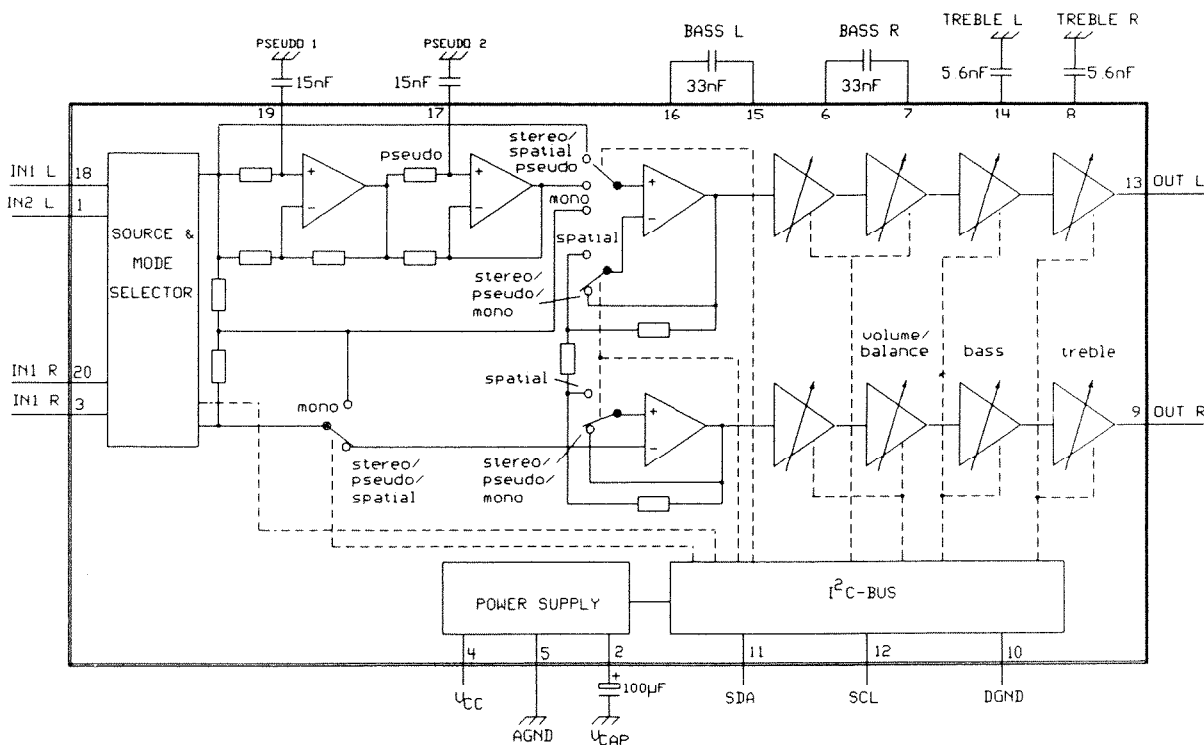

BLOCK DIAGRAM OF TDA8425

TDA2611A

5 W AUDIO POWER AMPLIFIER

GENERAL DESCRIPTION: The TDA2611A is a 5 watt, high supply voltage, audio amplifier used for sound power amplification purposes in TV broadcasting.

FEATURES :

- Possibility for increasing the input impedance
- Single in-line (SIL) construction for easy mounting
- Very suitable for application in mains-fed apparatus
- Extremely low number of external components
- Thermal protection
- Well defined open loop gain circuitry with simple quiescent current setting and fixed integrated closed loop gain

PINNING

PIN VOLTAGE

1. Supply Voltage Input	: 28V
2. Amplified Signal Output.....	: 2.2VPP 1KHz, 13.2V DC, 14.2V (Mute)
3. No Connection	: -
4. Ground.....	: -
5. No Connection	: -
6. Ground.....	: -
7. Input Signal.....	: 1.25V
8. No Connection	: -
9. Input Impedance	: -

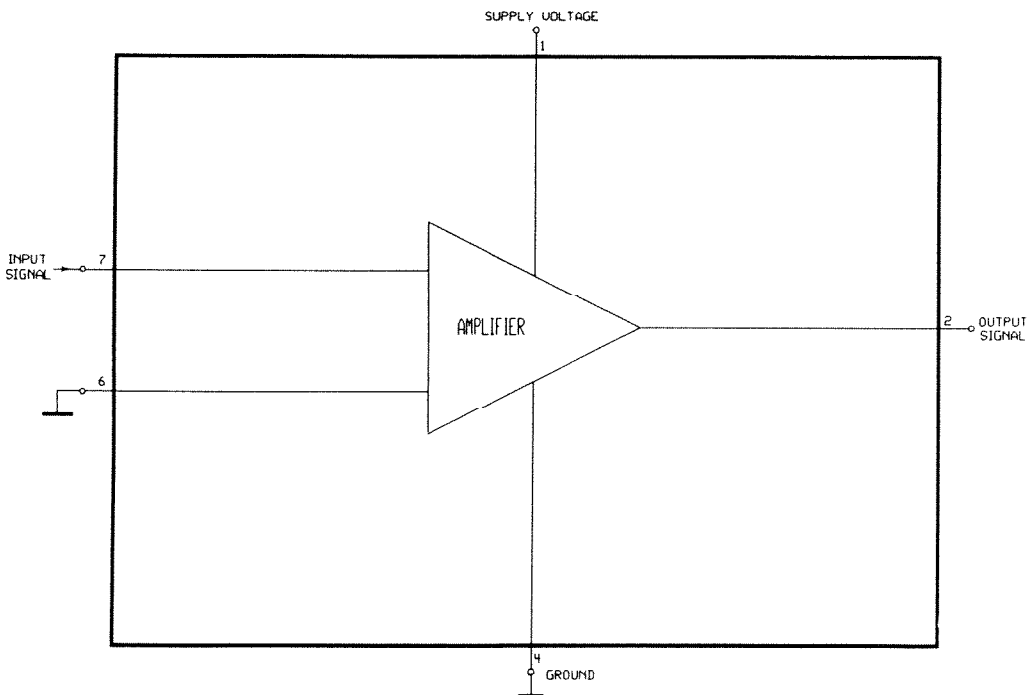

BLOCK DIAGRAM OF TDA2611A

PCF 84C81

SINGLE-CHIP 8-BIT MICROPHOTOGRAPH

GENERAL DESCRIPTION: An advanced CMOS process is used to manufacture the PCF 84C81 microcontroller. It has 20 quasi-bidirectional I/O port lines, a serial I/O interface, a single-level vectored interrupt structure, an 8-bit timer/event counter, on-chip clock oscillator and clock circuits. This efficient controller also perform well as arithmetic processor. It has facilities for both binary and BCD arithmetic plus bit-handling capabilities.

FEATURES:

- 8K x 8 ROM
- 256 x 8 RAM
- 20 quasi-bidirectional I/O port lines
- Two test inputs, one of which is also the external interrupt input
- Single-level vectored interrupts: external, timer/event counter and serial I/O
- Interface for serial data transfer on two lines (serial I/O data via an existing port line and clock via a dedicated line)
- 8-bit programmable timer/event counter
- Clock frequency range: 100 KHz to 10 MHz
- Over 80 instructions all of 1 or 2 cycles
- Single supply voltage (2.5 to 5.5 V)
- STOP and IDLE modes
- Power-on reset circuit
- Operating temperature range: -40 to +85 ° C

PINNING

	PIN VOLTAGE	
	WITH TEXT	WITHOUT TEXT
1. 4-bit I/O Port Bit 2 (P2.2)	5V	5V
2. 4-bit I/O Port Bit 3 (P2.3)	4.4V	4.4V
3. Bidirectional Clock for Serial I/O	4.4V	4.4V
4. 8-bit I/O Port Bit 0 (P0.0)	5V	5V
5. 8-bit I/O Port Bit 1 (P0.1)	5V	5V
6. 8-bit I/O Port Bit 2 (P0.2)	0V	0V
7. 8-bit I/O Port Bit 3 (P0.3)	4.18V	0V
8. 8-bit I/O Port Bit 4 (P0.4)	5V	5V
9. 8-bit I/O Port Bit 5 (P0.5)	0V	0V
10. 8-bit I/O Port Bit 6 (P0.6)	5V	5V
11. 8-bit I/O Port Bit 7 (P0.7)	0V	0V
12. Interrupt Input / Test Input 0	0.2V	0V
13. Test Input 1	0.2V	0V
14. Ground	0V	0V
15. Oscillator Input	2.46V	2.46V
16. Oscillator Output	2.46V	2.46V
17. Reset Input	5V	0V
18. 8-bit I/O Port Bit 0 (P1.0)	5V	5V
19. 8-bit I/O Port Bit 1 (P1.1)	5V	5V
20. 8-bit I/O Port Bit 2 (P1.2)	0V	5V
21. 8-bit I/O Port Bit 3 (P1.3)	0V	0V
22. 8-bit I/O Port Bit 4 (P1.4)	5V	5V
23. 8-bit I/O Port Bit 5 (P1.5)	0V	0V
24. 8-bit I/O Port Bit 6 (P1.6)	5V	5V
25. 8-bit I/O Port Bit 7 (P1.7)	0V	0V
26. 4-bit I/O Port Bit 0 (P2.0)	5V	5V
27. 4-bit I/O Port Bit 1 (P2.1)	5V	5V
28. Power Supply	5V	5V

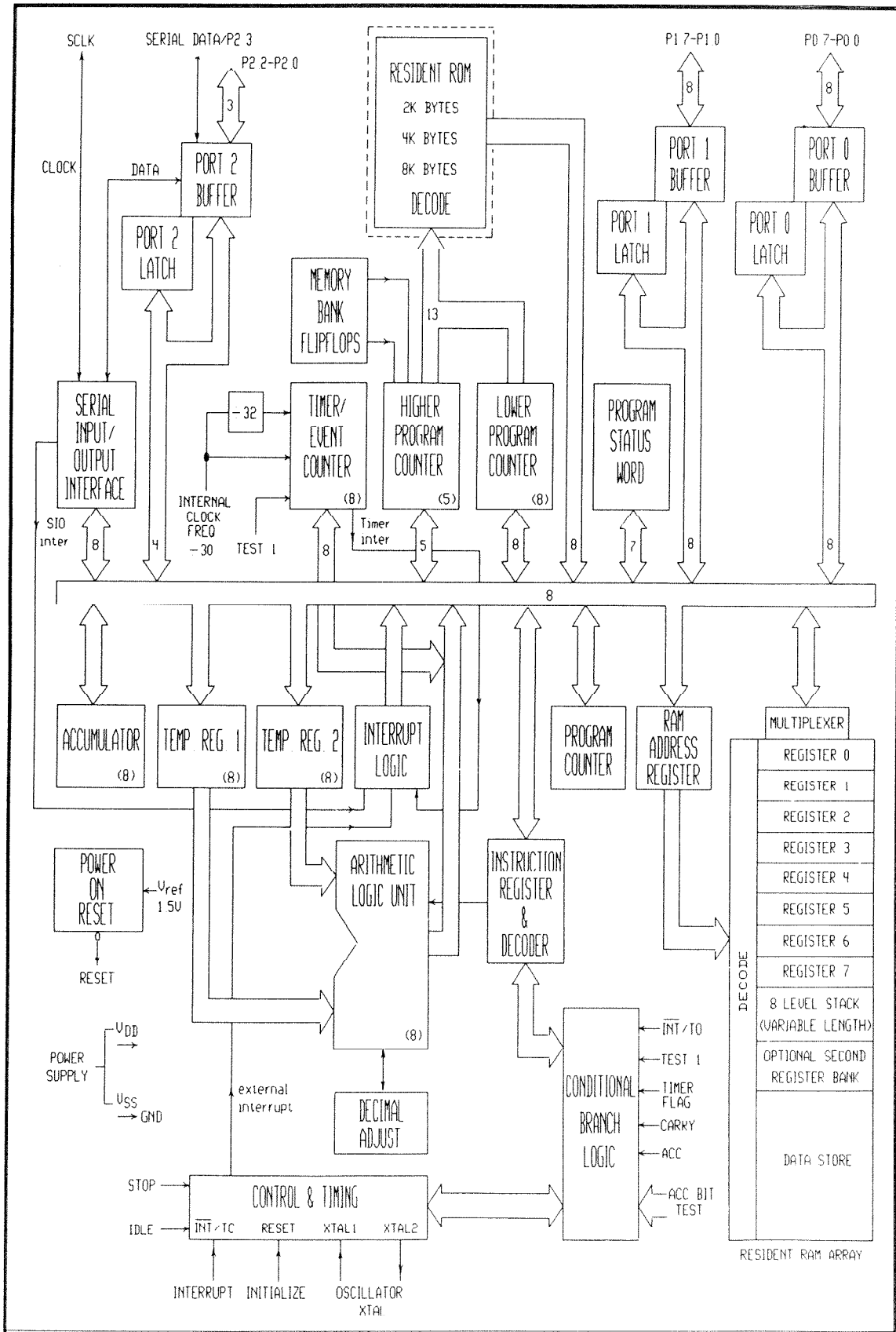

BLOCK DIAGRAM OF PCF84C81

ELECTRONIC COMPONENT PART LIST

	2038009810	CRT.B.ASSY.09E 21 PHL (10) N1	IC301	3621526110	IC TDA 2611A
C901	3051520030	CAP SMD 1.5NF 50V J COG	PL301	3861200201	CONN.MALE 2P TUNIK (2002)
C902	3055610030	CAP SMD 560PF 50V J	PL303	3864011104	PIN F 11P/2.5MM
C903	3061020146	CAP SER 1NF 50V K B	PL304	3864011404	PIN F 14P/2.5MM
C904	3055610030	CAP SMD 560PF 50V J	Q301	3611905480	TR BC548B
C905	3051520030	CAP SMD 1.5NF 50V J COG	R301	3311520437	RES CF 1/4W 1.5K J
C906	3055610030	CAP SMD 560PF 50V J	R302	3311220437	RES CF 1/4W 1.2K J
C907	3201021156	CAP CER 1NF 1KV M B	R303	3315610437	RES CF 1/4W 560R J
C909	3081010356	CAP EL 100UF 16V M	R304	3313930437	RES CF 1/4W 39K J
C910	3061020146	CAP SER 1NF 50V K B	R305	3311030437	RES CF 1/4W 10K J
C911	3061020146	CAP SER 1NF 50V K B	R306	3316890437	RES CF 1/4W 6.8K J
C912	3061020146	CAP SER 1NF 50V K B	R307	3364791137	RES FUSE 1W 4.7R J
C916	3054710030	CAP SMD 470PF 50V J	R309	3311530437	RES CF 1/4W 15K J
C917	3054710030	CAP SMD 470PF 50V J	S302	5913225000	JUMP WIRE 0.6MM
C918	3054710030	CAP SMD 470PF 50V J			
D901	3531941488	DIODE 1N4148 SMD			
D902	3551940030	DIODE 1N4003 TA			
D903	3551940030	DIODE 1N4003 TA			
D904	3551940030	DIODE 1N4003 TA			
D905	3531941488	DIODE 1N4148 SMD			
GND2	8073022504	RIVET BR 2.5*4.5			
L901	5913225000	JUMP WIRE 0.6MM			
L902	5913225000	JUMP WIRE 0.6MM			
L903	5913225000	JUMP WIRE 0.6MM			
PL602	4930360300	CON.ASSY 3/36 FLAMAN			
PL901	4930450600	CON.ASSY 6/45 (CRT)			
PL902	3862021000	SOCKET CRT NARROWNECK METALLO			
Q901	3611508690	TR BF869S			
Q902	3611508218	TR BF821 SMD			
Q903	3611508690	TR BF869S			
Q904	3611508218	TR BF821 SMD			
Q905	3611508690	TR BF869S			
Q906	3611508218	TR BF821 SMD			
Q907	3611908588	TR BC858B SMD			
R901	3311220830	RES SMD 1/8W 1.2K J			
R902	3311510830	RES SMD 1/8W 150R J			
R903	3821120600	JUMPER SMD 1206			
R904	3316840830	RES SMD 1/8W 680K J			
R905	3311220830	RES SMD 1/8W 1.2K J			
R906	3311520237	RES CF 1/2W 1.5K J			
R907	3351032137	RES MO 2W 10K J			
R908	3311820830	RES SMD 1/8W 1.8K J			
R909	3311510830	RES SMD 1/8W 150R J			
R910	3821120600	JUMPER SMD 1206			
R911	3316840830	RES SMD 1/8W 680K J			
R912	3311220830	RES SMD 1/8W 1.2K J			
R913	3311520237	RES CF 1/2W 1.5K J			
R914	3351032137	RES MO 2W 10K J			
R915	3351002135	RES MO 2W 10R J			
R916	3311510830	RES SMD 1/8W 150R J			
R917	3821120600	JUMPER SMD 1206			
R918	3316840830	RES SMD 1/8W 680K J			
R919	3311220830	RES SMD 1/8W 1.2K J			
R920	3311520237	RES CF 1/2W 1.5K J			
R921	3351032137	RES MO 2W 10K J			
R922	3311510830	RES SMD 1/8W 150R J			
R923	3315620830	RES SMD 1/8W 5.6K J			
R925	3314740237	RES CF 1/2W 470K J			
R926	3313300830	RES SMD 1/8W 33R J			
R927	3319130830	RES SMD 1/8W 91K J			
R928	3311540830	RES SMD 1/8W 150K J			
R929	3311220830	RES SMD 1/8W 1.2K J			
R952	3314710830	RES SMD 1/8W 470R J			
SCREE	5353035051	TEST PIN 1.1MM			
VR951	3341021200	RES ADJ 1/6W 1K K HOR.			
VR953	3341021200	RES ADJ 1/6W 1K K HOR.			
	2042001030	SOUND B.ASSY.11SD02 (16R)			
C301	3081020554	CAP EL 1000UF 35V M	C301	3081020554	CAP EL 1000UF 35V M
C302	3011041036	CAP MKT 100NF 63V J	C302	3061020146	CAP SER 1NF 50V K B
C303	3062230396	CAP SER 22NF 50V Z F	C303	3061020146	CAP SER 1NF 50V K B
C304	3062230396	CAP SER 22NF 50V Z F	C304	3061020146	CAP SER 1NF 50V K B
C305	3084710854	CAP EL 470UF 50V M	C305	3061020146	CAP SER 1NF 50V K B
C306	3011041036	CAP MKT 100NF 63V J	C306	3061020146	CAP SER 1NF 50V K B
C308	3082290856	CAP EL 2.2UF 50V M	C307	3061020146	CAP SER 1NF 50V K B
D301	3531941480	DIODE 1N4148	C308	3052700136	CAP SER 27PF 50V J CH
D302	3531941480	DIODE 1N4148	C309	3052700136	CAP SER 27PF 50V J CH
D303	3571922000	DIODE ZENER ZPD22V	C310	3061020146	CAP SER 1NF 50V K B
			C311	3061020146	CAP SER 1NF 50V K B
			C312	3061020146	CAP SER 1NF 50V K B
			C313	3053390136	CAP CER 3.3PF 50V J CH
			C315	3061020146	CAP SER 1NF 50V K B
			C316	3053390136	CAP CER 3.3PF 50V J CH
			C317	3062247396	CAP CER 220NF 25V Z F
			C318	3081000856	CAP EL 10UF 50V M
			C319	3061030396	CAP SER 10NF 50V Z F
			C320	3062247396	CAP CER 220NF 25V Z F
			C321	3062247396	CAP CER 220NF 25V Z F
			C322	3084790856	CAP EL 4.7UF 50V M
			C323	3084790856	CAP EL 4.7UF 50V M
			C324	3062230396	CAP SER 22NF 50V Z F
			C325	3011041036	CAP MKT 100NF 63V J
			C326	3011041036	CAP MKT 100NF 63V J
			C327	3011041036	CAP MKT 100NF 63V J
			C328	3062230396	CAP SER 22NF 50V Z F
			C329	3084710854	CAP EL 470UF 50V M
			C330	3082290856	CAP EL 2.2UF 50V M
			D301	3531941488	DIODE 1N4148 SMD
			D302	3531941480	DIODE 1N4148
			D303	3571922000	DIODE ZENER ZPD22V
			D304	3531941488	DIODE 1N4148 SMD
			IC301	3621550300	IC TDA 5030A
			IC302	3621598300	IC TDA9830
			IC303	3621526110	IC TDA 2611A
			L301	4011140011	FIXED COIL 1.47UH (L101)
			PL301	3861200201	CONN.MALE 2P TUNIK (2002)
			PL303	3861501102	CONN.FEMALE 11P MOLEX (AHPB)
			PL304	3861501402	CONN.FEMALE 14P MOLEX
			Q301	3611905480	TR BC548B
			Q302	3611905480	TR BC548B
			Q306	3611908488	TR BC848B SMD
			Q307	3611908488	TR BC848B SMD
			Q308	3611908588	TR BC858B SMD
			Q309	3611908488	TR BC848B SMD
			Q310	3611908588	TR BC858B SMD
			Q311	3611908588	TR BC858B SMD
			R301	3311020830	RES SMD 1/8W 1K J
			R302	3312730437	RES CF 1/4W 27K J
			R303	3313330830	RES SMD 1/8W 33K J
			R304	3313930437	RES CF 1/4W 39K J
			R305	3311030437	RES CF 1/4W 10K J
			R306	3316890437	RES CF 1/4W 6.8K J
			R307	3364791137	RES FUSE 1W 4.7R J
			R308	3316820437	RES CF 1/4W 6.8K J
			R309	3315610437	RES CF 1/4W 560R J
			R310	3311020437	RES CF 1/4W 1K J
			R312	3311220437	RES CF 1/4W 1.2K J
			R313	3314710830	RES SMD 1/8W 470R J
			R314	3314710830	RES SMD 1/8W 470R J
			R315	3311510830	RES SMD 1/8W 150R J

C369	3012241036	CAP MKT 220NF 63V J	R03	3311030830	RES SMD 1/8W 10K J
C374	3082290856	CAP EL 2.2UF 50V M	R04	3311030830	RES SMD 1/8W 10K J
C375	3082290856	CAP EL 2.2UF 50V M	R05	3311040830	RES SMD 1/8W 100K J
IC301	3621538570	IC TDA3857	R06	3311040830	RES SMD 1/8W 100K J
IC302	3621584160	IC TDA 8416	R07	3314730830	RES SMD 1/8W 47K J
IC303	3621584250	IC TDA 8425V/7	R08	3311020830	RES SMD 1/8W 1K J
IC304	3621515210	IC TDA1521A	R09	3314730830	RES SMD 1/8W 47K J
LT301	4020006031	ADJ.COIL VIF 38.9MHZ 0=60	R10	3311030830	RES SMD 1/8W 10K J
LT302	4020003030	ADJ.COIL 113CNS-K1763HM	R11	3311040830	RES SMD 1/8W 100K J
LT303	4020003030	ADJ.COIL 113CNS-K1763HM	R12	3311040830	RES SMD 1/8W 100K J
PL301	3861200200	CONN.MALE 2P TUNIK (2702)	R13	3314730830	RES SMD 1/8W 47K J
PL302	3861200200	CONN.MALE 2P TUNIK (2702)	R14	3311020830	RES SMD 1/8W 10K J
PL303	3861501102	CONN.FEMALE 11P MOLEX (AHPB)	R15	3314730830	RES SMD 1/8W 47K J
PL304	3861501402	CONN.FEMALE 14P MOLEX	R16	3311030830	RES SMD 1/8W 10K J
Q301	3611908488	TR BC848B SMD	R17	3311040830	RES SMD 1/8W 100K J
Q302	3611908488	TR BC848B SMD	R18	3311040830	RES SMD 1/8W 100K J
R301	3315610830	RES SMD 1/8W 560R J	R19	3314730830	RES SMD 1/8W 47K J
R302	3315610830	RES SMD 1/8W 560R J	R20	3311020830	RES SMD 1/8W 1K J
R304	3314710830	RES SMD 1/8W 470R J	R21	3314730830	RES SMD 1/8W 47K J
R305	3314710830	RES SMD 1/8W 470R J	R22	3317500830	RES SMD 1/8W 75R J
R307	3311010830	RES SMD 1/8W 100R J			
R308	3311010830	RES SMD 1/8W 100R J			
R313	3311040830	RES SMD 1/8W 100K J			
R314	3363391529	RES FUSE 1.5W 3.3R K			
R322	3313330830	RES SMD 1/8W 33K J			
R323	3313330830	RES SMD 1/8W 33K J			
R324	3311020830	RES SMD 1/8W 1K J			
R325	3311030830	RES SMD 1/8W 10K J			
R326	3311030830	RES SMD 1/8W 10K J			
R330	3311030830	RES SMD 1/8W 10K J			
R331	3311030830	RES SMD 1/8W 10K J			
R334	3313330830	RES SMD 1/8W 3.3K J			
R335	3313310830	RES SMD 1/8W 330R J			
R338	3313330830	RES SMD 1/8W 3.3K J			
R339	3311030830	RES SMD 1/8W 10K J			
R340	3311030830	RES SMD 1/8W 10K J			
R341	3313310830	RES SMD 1/8W 330R J			
R350	3311030830	RES SMD 1/8W 10K J			
R351	3318220830	RES SMD 1/8W 8.2K J			
R360	3311020830	RES SMD 1/8W 1K J			
R361	3314720830	RES SMD 1/8W 4.7K J			
R362	3311020830	RES SMD 1/8W 1K J			
R363	3314720830	RES SMD 1/8W 4.7K J			
VR301	3341031210	RES ADJ 1/8W 10K K VER.			
X301	3840110020	XTAL 10MHZ			
Z301	3750292510	FILTER SAW OFWG9251M			
Z302	3760105701	FILTER SER SFT 5.74MA			
Z303	3760105501	FILTER SER SFT 5.5MA			
	2046400100	SOUND B.ASSY.SS02 DOUBLE SCART			
C01	3014741036	CAP MKT 470NF 63V J			
C02	3014741036	CAP MKT 470NF 63V J			
C03	3014741036	CAP MKT 470NF 63V J			
C04	3014741036	CAP MKT 470NF 63V J			
C05	3014741036	CAP MKT 470NF 63V J			
C06	3014741036	CAP MKT 470NF 63V J			
D01	3531941480	DIODE 1N4148			
D02	3531941480	DIODE 1N4148			
D03	3531941480	DIODE 1N4148			
D04	3531941480	DIODE 1N4148			
D05	3531941480	DIODE 1N4148			
D06	3531941480	DIODE 1N4148			
PL01	3864010800	PIN F 8P/2.5MM			
Q01	3611908488	TR BC848B SMD			
Q013	3611908488	TR BC848B SMD			
Q015	3611908488	TR BC848B SMD			
Q02	3611908488	TR BC848B SMD			
Q03	3611908488	TR BC848B SMD			
Q04	3611908588	TR BC858B SMD			
Q05	3611908488	TR BC848B SMD			
Q06	3611908488	TR BC848B SMD			
Q07	3611908488	TR BC848B SMD			
Q08	3611908488	TR BC848B SMD			
Q09	3611908488	TR BC848B SMD			
Q10	3611908488	TR BC848B SMD			
Q11	3611908488	TR BC848B SMD			
Q12	3611908488	TR BC848B SMD			
Q14	3611908488	TR BC848B SMD			
R01	3311030830	RES SMD 1/8W 10K J			
R02	3311030830	RES SMD 1/8W 10K J			
				2042601400	SOUND B.ASSY.GN03 (NI-BG)
			C301	3054720030	CAP SMD 4.7NF 50V J
			C302	3061030240	CAP SMD 10NF 50V K
			C303	3013341036	CAP MKT 330NF 63V J
			C304	3054720030	CAP SMD 4.7NF 50V J
			C305	3064730240	CAP SMD 47NF 50V K X7R
			C309	3061040240	CAP SMD 100NF 50V K
			C310	3062230240	CAP SMD 22NF 50V K R
			C311	3081000856	CAP EL 10UF 50V M
			C312	3061030240	CAP SMD 10NF 50V K
			C313	3082200856	CAP EL 22UF 50V M
			C314	3061040240	CAP SMD 100NF 50V K
			C315	3081000856	CAP EL 10UF 50V M
			C316	3061030240	CAP SMD 10NF 50V K
			C318	3081000856	CAP EL 10UF 50V M
			C319	3081090856	CAP EL 1UF 50V M
			C320	3081000856	CAP EL 10UF 50V M
			C321	3061040240	CAP SMD 100NF 50V K
			C322	3012231136	CAP MKT 22NF 100V J
			C323	3061040240	CAP SMD 100NF 50V K
			C324	3084700856	CAP EL 47UF 50V M
			C325	3084700856	CAP EL 47UF 50V M
			C326	3081000856	CAP EL 10UF 50V M
			C327	3013341036	CAP MKT 330NF 63V J
			C328	3061030240	CAP SMD 10NF 50V K
			C329	3081000856	CAP EL 10UF 50V M
			C330	3012231136	CAP MKT 22NF 100V J
			C333	3051000020	CAP SMD 10PF 50V D COG
			C335	3052210030	CAP SMD 220PF 50V J
			C337	3061030240	CAP SMD 10NF 50V K
			C338	3081000856	CAP EL 10UF 50V M
			C339	3012231136	CAP MKT 22NF 100V J
			C340	3061030240	CAP SMD 10NF 50V K
			C341	3051010030	CAP SMD 100PF 50V J
			C342	3061030240	CAP SMD 10NF 50V K
			C343	3051010030	CAP SMD 100PF 50V J
			C344	3062230240	CAP SMD 22NF 50V K R
			C345	3081000856	CAP EL 10UF 50V M
			C348	3012231136	CAP MKT 22NF 100V J
			C349	3014741036	CAP MKT 470NF 63V J
			C350	3061040240	CAP SMD 100NF 50V K
			C351	3081010356	CAP EL 100UF 16V M
			C355	3011041036	CAP MKT 100NF 63V J
			C356	3081010356	CAP EL 100UF 16V M
			C357	3014731036	CAP MKT 47NF 63V J
			C358	3014741036	CAP MKT 470NF 63V J
			C360	3012231136	CAP MKT 22NF 100V J
			C361	3012231136	CAP MKT 22NF 100V J
			C362	3081010556	CAP EL 100UF 35V M
			C363	3081020554	CAP EL 1000UF 35V M
			C364	3011041036	CAP MKT 100NF 63V J
			C365	3081020554	CAP EL 1000UF 35V M
			C366	3081020554	CAP EL 1000UF 35V M
			C368	3082290856	CAP EL 2.2UF 50V M
			C369	3062230240	CAP SMD 22NF 50V K R
			C370	3011031036	CAP MKT 10NF 63V J
			C371	3011031036	CAP MKT 10NF 63V J
			C372	3821120600	JUMPER SMD 1206
			C373	3061020146	CAP SER 1NF 50V K B

R01	3315610237	RES CF 1/2W 560R J	C703	3062220146	CAP SER 2.2NF 50V K B
R02	3315610237	RES CF 1/2W 560R J	C704	3011041036	CAP MKT 100NF 63V J
S02	5913225000	JUMP WIRE 0.6MM	C705	3083390856	CAP EL 3.3UF 50V M
S04	5913225000	JUMP WIRE 0.6MM	C706	3081020554	CAP EL 1000UF 35V M
			C707	3081011056	CAP EL 100UF 63V M
			C708	3082210656	CAP EL 220UF 40V M
			C801	3011041558	CAP MKT 100NF 250V M AC
			C802	3011041558	CAP MKT 100NF 250V M AC
			C803	3011041558	CAP MKT 100NF 250V M AC
			C804	3201021156	CAP CER 1NF 1KV M B
			C805	3201021156	CAP CER 1NF 1KV M B
			C806	3201021156	CAP CER 1NF 1KV M B
			C807	3201021156	CAP CER 1NF 1KV M B
			C808	3121511950	CAP EL 150UF 385V M
			C809	3012241036	CAP MKT 220NF 63V J
			C810	3013921036	CAP MKT 3.9NF 63V J
			C811	3064710146	CAP SER 470PF 50V B K
			C812	3084700556	CAP EL 47UF 35V M
			C813	3064720146	CAP SER 4.7NF 50V K B
			C814	3023335044	CAP PP 33NF 630V K
			C816	3032215048	CAP MPP 0.22NF 630V K
			C817	3081090856	CAP EL 1UF 50V M
			C818	3084701358	CAP EL 47UF 160V M (HR)
			C819	3084710854	CAP EL 470UF 50V M
			C820	3081000856	CAP EL 10UF 50V M
			C821	3081020454	CAP EL 1000UF 25V M
			C823	3082210356	CAP EL 220UF 16V M
			C824	3202227458	CAP SER 2.2NF 4KV M
			C825	3062247396	CAP CER 220NF 25V Z F
			C826	3061040396	CAP SER 100NF 50V Z F
			C827	3081010456	CAP EL 100UF 25V M
			C829	3062714146	CAP SER 270PF 500V K B
			C833	3081020554	CAP EL 1000UF 35V M
			C834	3061040396	CAP SER 100NF 50V Z F
			C835	3061040396	CAP SER 100NF 50V Z F
			D201	3531941480	DIODE 1N4148
			D402	3531941480	DIODE 1N4148
			D403	5913225000	JUMP WIRE 0.6MM
			D405	5913225000	JUMP WIRE 0.6MM
			D504	3531941480	DIODE 1N4148
			D505	3531941480	DIODE 1N4148
			D506	3531941480	DIODE 1N4148
			D507	3531941480	DIODE 1N4148
			D508	3531941480	DIODE 1N4148
			D513	3531941480	DIODE 1N4148
			D528	3531941480	DIODE 1N4148
			D601	3531941480	DIODE 1N4148
			D602	3531941480	DIODE 1N4148
			D603	3551949370	DIODE 1N4937
			D604	3551949370	DIODE 1N4937
			D701	3551940030	DIODE 1N4003 TA
			D801	3551940070	DIODE 1N4007
			D802	3551940070	DIODE 1N4007
			D803	3551940070	DIODE 1N4007
			D804	3551940070	DIODE 1N4007
			D806	3531941480	DIODE 1N4148
			D807	3531941480	DIODE 1N4148
			D808	3551949370	DIODE 1N4937
			D810	3551949370	DIODE 1N4937
			D811	3551500261	DIODE BYM26D
			D812	3551949370	DIODE 1N4937
			D813	3571933000	DIODE ZENER 33V UZT 33B
			D814	3551902981	DIODE BY298 (AK06)
			D815	3570006800	DIODE ZENER 6.8V
			D820	3571905100	DIODE ZENER ZPD 5.1V
			F801	3807250050	FUSE 2.5A 250V 5*20MM
			IC402	3621546611	IC TDA 4661 V2B
			IC701	3621536532	IC TDA3653B/N2
			IC801	3621846050	IC TDA4605-2
			L201	4011104512	FIXED COIL 1UH Q45 M-A
			L401	4011680032	FIXED COIL 6.8UH J AXI
			L405	4012106522	FIXED COIL 10UH Q65 K-A
			L501	4262125026	CHOK PEAKING COIL 12UH Q50 K
			L601	4090109000	LINEARITY COIL 50UH (06-06A)
			L801	4013150017	COIL CHOKE 150UH 0.82A RAD
			LT401	4020006031	ADJ.COIL VIF 38.9MHZ 0=60
			PL601	3861820304	CONN.MALE 3P (EKINLER)
			PL602	3861820404	CONN.MALE 4P (EKINLER)
			PL701	3861200400	CONN.MALE 4P TUNIK (2004)
			PL802	3864010301	PIN 3P TELESET (PL802)
			PL901	3861200601	CONN.MALE 6P TUNIK (2006)
			Q201	3611905480	TR BC548B
	5105135040	MAIN B.ASSY.10-COMMON			
	5120030003	SPRING TR.HOLDER (MEDIUM)			
112V	5353035051	CHASSIS BRACKET AK10			
C-C	4942010001	TEST PIN 1.1MM			
C201	3081000856	CABLE 0.6MM BLUE			
C202	3084700556	CAP EL 10UF 50V M			
C203	3061030396	CAP EL 47UF 35V M			
C206	3011041036	CAP SER 10NF 50V Z F			
C207	3064720146	CAP MKT 100NF 63V J			
C210	3081000856	CAP SER 4.7NF 50V K B			
C401	3063920146	CAP EL 10UF 50V M			
C404	3011041036	CAP CER 3.9NF 50V K B			
C405	3062230396	CAP MKT 100NF 63V J			
C406	3081000856	CAP SER 22NF 50V Z F			
C407	3064730396	CAP EL 10UF 50V M			
C408	3064730396	CAP SER 47NF 50V Z F			
C409	3011041036	CAP SER 47NF 50V Z F			
C410	3051010836	CAP MKT 100NF 63V J			
C411	3061020146	CAP SER 100PF 50V J SL			
C414	3061040396	CAP SER 1NF 50V K B			
C415	3061040396	CAP SER 100NF 50V Z F			
C416	3061020146	CAP SER 100NF 50V Z F			
C417	3061020146	CAP SER 1NF 50V K B			
C418	3061040396	CAP SER 1NF 50V K B			
C419	3064720146	CAP SER 100NF 50V Z F			
C420	3051800636	CAP SER 4.7NF 50V K B			
C421	3081000856	CAP SER 18PF 50V J SL			
C422	3081090856	CAP EL 10UF 50V M			
C423	3064720146	CAP EL 1UF 50V M			
C424	3062220146	CAP SER 4.7NF 50V K B			
C425	3064710146	CAP SER 2.2NF 50V K B			
C426	3023330036	CAP SER 470PF 50V B K			
C427	3012231136	CAP KP 33NF 63V J			
C428	3082290856	CAP MKT 22NF 100V J			
C429	3081000856	CAP EL 2.2UF 50V M			
C430	3062230396	CAP EL 10UF 50V M			
C431	3082290856	CAP SER 22NF 50V Z F			
C434	3011041036	CAP EL 2.2UF 50V M			
C435	3011041036	CAP MKT 100NF 63V J			
C436	3011041036	CAP MKT 100NF 63V J			
C438	3083390856	CAP EL 3.3UF 50V M			
C445	3011041036	CAP MKT 100NF 63V J			
C446	3061040396	CAP SER 100NF 50V Z F			
C451	3054700836	CAP SER 47PF 50V J SL			
C456	3064730396	CAP SER 47NF 50V Z F			
C464	3081010356	CAP EL 100UF 16V M			
C487	3081000856	CAP EL 10UF 50V M			
C495	3011021046	CAP MKT 1NF 63V K			
C501	3051010836	CAP SER 100PF 50V J SL			
C502	3012241036	CAP MKT 220NF 63V J			
C503	3011041036	CAP MKT 100NF 63V J			
C504	3061040396	CAP SER 100NF 50V Z F			
C506	3084790856	CAP EL 4.7UF 50V M			
C507	3081090856	CAP EL 1UF 50V M			
C508	3084790856	CAP EL 4.7UF 50V M			
C509	3062220146	CAP SER 2.2NF 50V K B			
C513	3061040396	CAP SER 100NF 50V Z F			
C515	3061040396	CAP SER 100NF 50V Z F			
C601	3014721136	CAP MKT 4.7NF 100V J			
C602	3014741036	CAP MKT 470NF 63V J			
C604	3011041548	CAP MKT 100NF 250V K			
C605	3083391356	CAP EL 3.3UF 160V M			
C606	3034341538	CAP MKP 430NF 250V J			
C607	3083301356	CAP EL 33UF 160V M			
C608	3081001456	CAP EL 10UF 250V M			
C609	3032243058	CAP MKP 220NF 250V M			
C610	3014731136	CAP MKT 47NF 100V J			
C611	3012231136	CAP MKT 22NF 100V J			
C612	3016821136	CAP MKT 6.8NF 100V J			
C613	3062220146	CAP SER 2.2NF 50V K B			
C614	3204094846	CAP CER 4PF 2KV K SL			
C615	3051010836	CAP SER 100PF 50V J SL			
C701	3064720146	CAP SER 4.7NF 50V K B			
C702	3064720146	CAP SER 4.7NF 50V K B			

Q401	3611905480	TR BC548B	R611	3312240437	RES CF 1/4W 220K J
Q403	3611905480	TR BC548B	R612	3312430437	RES CF 1/4W 24K J
Q404	3611905480	TR BC548B	R613	3312230437	RES CF 1/4W 22K J
Q408	3611905480	TR BC548B	R614	3314720437	RES CF 1/4W 4.7K J
Q501	3611502400	TR BF240	R615	3313330437	RES CF 1/4W 33K J
Q509	3611905580	TR BC558B	R616	3311030437	RES CF 1/4W 10K J
Q601	3611506390	TR BC639	R617	3311040437	RES CF 1/4W 100K J
Q603	3611905480	TR BC548B	R618	3312730437	RES CF 1/4W 27K J
Q604	3611905480	TR BC548B	R619	3311530437	RES CF 1/4W 15K J
Q605	3611905480	TR BC548B	R701	3313920437	RES CF 1/4W 3.9K J
Q701	3611905480	TR BC548B	R702	3311030437	RES CF 1/4W 10K J
Q702	3611905580	TR BC558B	R703	3318230437	RES CF 1/4W 82K J
Q801	3611800771	TR BUZ77B	R704	3312230437	RES CF 1/4W 22K J
Q802	3611502380	TR BD238	R705	3311830437	RES CF 1/4W 18K J
Q803	3611905580	TR BC558B	R706	3321890257	RES MF 1/2W 1.8R G
Q804	3611905480	TR BC548B	R708	3354712134	RES MO 2W 470R
R201	3311030437	RES CF 1/4W 10K J	R709	3314710437	RES CF 1/4W 470R J
R202	3313330437	RES CF 1/4W 33K J	R710	3316810437	RES CF 1/4W 680R J
R203	3311030437	RES CF 1/4W 10K J	R711	3364791137	RES FUSE 1W 4.7R J
R204	3311220437	RES CF 1/4W 1.2K J	R715	3311020437	RES CF 1/4W 1K J
R205	3314720437	RES CF 1/4W 4.7K J	R716	3316820437	RES CF 1/4W 6.8K J
R402	3316820437	RES CF 1/4W 6.8K J	R801	3382295130	RES WW 5W 2.2R J RAD.
R403	3311020437	RES CF 1/4W 1K J	R802	3311040237	RES CF 1/2W 100K J
R405	3313910437	RES CF 1/4W 390R J	R803	3315620437	RES CF 1/4W 5.6K J
R406	3311020437	RES CF 1/4W 1K J	R804	3318240237	RES CF 1/2W 820K J
R407	3311510437	RES CF 1/4W 150R J	R805	3313341137	RES CF 330K 1W J
R409	3311020437	RES CF 1/4W 1K J	R806	3311830437	RES CF 1/4W 18K J
R410	3318210437	RES CF 1/4W 820R J	R807	3313910437	RES CF 1/4W 390R J
R412	3317500437	RES CF 1/4W 75R J	R808	3311030437	RES CF 1/4W 10K J
R421	3317500437	RES CF 1/4W 75R J	R809	3364781137	RES FUS 0.47R 1W J
R422	3317500437	RES CF 1/4W 75R J	R810	3311010437	RES CF 1/4W 100R J
R423	3317500437	RES CF 1/4W 75R J	R811	5913225000	JUMP WIRE 0.6MM
R425	3318220437	RES CF 1/4W 8.2K J	R812	3354701137	RES MO 1W 47R J
R426	3311030437	RES CF 1/4W 10K J	R813	3311030437	RES CF 1/4W 10K J
R427	3311040437	RES CF 1/4W 100K J	R814	3314720437	RES CF 1/4W 4.7K J
R428	3313330437	RES CF 1/4W 33K J	R815	3353332137	RES MO 33K 2W J
R430	3311030437	RES CF 1/4W 10K J	R816	3374750237	RES MG 1/2W 4.7M J
R431	3311030437	RES CF 1/4W 10K J	R817	3363391529	RES FUSE 1.5W 3.3R K
R432	3316850437	RES CF 1/4W 6.8M J	R818	3312230237	RES CF 1/2W 22K J
R437	3311040437	RES CF 1/4W 100K J	R821	3311030437	RES CF 1/4W 10K J
R438	3311530437	RES CF 1/4W 15K J	R822	3311030437	RES CF 1/4W 10K J
R439	3311010437	RES CF 1/4W 100R J	R823	3318210437	RES CF 1/4W 820R J
R440	3313940437	RES CF 1/4W 390K J	R824	3311010437	RES CF 1/4W 100R J
R441	3321060457	RES MF 1/4W 10M G	R825	3311240437	RES CF 1/4W 120K J
R442	3313340437	RES CF 1/4W 330K J	R826	3311040237	RES CF 1/2W 100K J
R443	3315620437	RES CF 1/4W 5.6K J	S602	5913225000	JUMP WIRE 0.6MM
R444	3311030437	RES CF 1/4W 10K J	S603	5913225000	JUMP WIRE 0.6MM
R445	3317500437	RES CF 1/4W 75R J	SC401	3862050004	SOCKET SCART (R)
R455	3317500437	RES CF 1/4W 75R J	TH801	3391803000	THERM.PTC DEGAUSS DUAL 250V
R457	3318240437	RES CF 1/4W 820K J	TP2	5353035051	TEST PIN 1.1MM
R460	3311020437	RES CF 1/4W 1K J	TR601	4050001901	LINE DRIVER TRF 90'
R469	3311020437	RES CF 1/4W 1K J	TR602	4030001901	TRF FBT 90'
R473	3316220437	RES CF 1/4W 6.2K J	TR801	4060001100	LINE FILTER 2*27MH
R480	3311020437	RES CF 1/4W 1K J	TR802	4040504910	TRF SMPS AK10
R481	3311020437	RES CF 1/4W 1K J	VR401	3341031100	RES ADJ 10K 1/6W M HOR
R482	3311020437	RES CF 1/4W 1K J	VR402	3341031100	RES ADJ 10K 1/6W M HOR
R501	3315620437	RES CF 1/4W 5.6K J	VR701	3344723310	RES ADJ 1/6W 4.7K J HOR.
R502	3311520437	RES CF 1/4W 1.5K J	VR702	3341011100	RES ADJ 100R 1/6W M HOR
R503	3311040437	RES CF 1/4W 100K J	VR703	3341031100	RES ADJ 10K 1/6W M HOR
R504	3311530437	RES CF 1/4W 15K J	VR801	3342521100	RES ADJ 2.5K 1/6W M HOR
R505	3311030437	RES CF 1/4W 10K J	X401	3840144310	XTAL 4.433619 MHZ
R506	3313930437	RES CF 1/4W 39K J			
R528	5913225000	JUMP WIRE 0.6MM			
R529	5913225000	JUMP WIRE 0.6MM			
R530	5913225000	JUMP WIRE 0.6MM			
R537	3314720437	RES CF 1/4W 4.7K J			
R538	3313320437	RES CF 1/4W 3.3K J			
R539	3313320437	RES CF 1/4W 3.3K J			
R543	3311020437	RES CF 1/4W 1K J			
R551	3311010437	RES CF 1/4W 100R J			
R552	3311010437	RES CF 1/4W 100R J			
R571	3311030437	RES CF 1/4W 10K J			
R572	3311020437	RES CF 1/4W 1K J			
R601	3314720437	RES CF 1/4W 4.7K J			
R602	3311020437	RES CF 1/4W 1K J			
R603	3314710437	RES CF 1/4W 470R J			
R604	3353312137	RES MO 2W 330R J			
R605	3314700437	RES CF 1/4W 47R J			
R606	3372240237	RES MG 1/4W 220K J			
R607	3352222137	RES MO 2W 2.2K J			
R609	3311040437	RES CF 1/4W 100K J			
R610	3311030437	RES CF 1/4W 10K J			

